



**Ministry of Public Works
Department of Works and Engineering**

**Request for Proposals
For
Installation of Two Overhead Refuse Cranes and Associated Equipment**

ADDENDUM 2

Request for Proposals No.: **2023-003-TB**

Addendum Issued: **Tuesday October 31, 2023**

Submission Deadline: **Friday November 10, 2023 at 3:00:00 PM** Bermuda Local Time

ADDENDUM 2

1. The following questions have been received from potential bidders.

#	Question	Answer
1	Please may we have an extension to the tender closing date of Wednesday 1 November 2023 at 3:00pm to Friday 10 November 2023 at 3:00pm?	Agreed, see Addendum #1 for all the revised dates.
2	Please provide details of the grabs, particularly the details of the orange peel blades and hydraulic systems to be installed following delivery. At what degree of disassembly will the grapple be shipped and will detailed assembly instructions be provided by the manufacturer.	A request has been put into the supplier, Peiner, but nothing has been received so far. We know that the grabs will be sent in 20' containers and the blades will not be attached to the hub. Please assume full re-assemble in your proposal.
3	Owner supplied list Annex D Item 4 notes "Complete electrical supply and control system for the crane(s)". Please confirm that this includes the power and control wiring between the MCR and the cranes, the MCR and the control stations, and the crane and the control stations. This question is asked because on the last contract with Kone, this interconnection wiring (Kone referred to this Building wiring), was not included in their supply scope.	Konecranes response; "No we only supplying the runway festoon. No building interconnection cabling. Same as the previous project scope of supply."
4	If supply of above interconnection wiring is not in contractor's scope to supply as detailed in annex H, page 31, item 8 - please provide a complete cable list for all required "building" wiring.	Konecranes response; "Will provide." We will forward this information when it is received.
5	In Owner supplied list Annex D Item 12, what is meant by the Owner supplying "Quality Control"?	The Quality Control refers to the quality of the items being supplied to the successful Proponent.
6	In Owner supplied list Annex D Item 16, what is meant by the Owner supplying "Erection supervision, training and commissioning"?	It is our intention to provide technical assistance during the works, as needed. The Proponent remains in control of the Works but a Konecranes representative will be available for consultation.
7	Please confirm that provision of internet connection at crane, MCR and/or control stations for purposes of remote monitoring and troubleshooting will be provided by Tynes Bay and is not the responsibility of the Contractor. Annex H - Page 3/6 Item 16	This is required to be Contractor supplied and installed, however, the complete scope of work for this task has not been defines. The Proponent shall provide an "allowance" in their proposal to cover this work. The allowance will be revised or confirmed as the scope is defined.

8	Please confirm that the MCR located control panels will be supplied in knocked down manner. i.e. each section (with double door) is supplied separately and is provided with "plug and play" connectors and all necessary wiring to remake the interconnections between control panel sections. Note the Kone Offer Annex H Page 4 1.2 item 4 referees "similar to the Ash Crane", however, the panels for the Ash crane were not supplied slit into sections.	The control panels will be supplied per the provided shop drawings showing the "shipping splits". There will be wires to be connected between panels and these will be properly labeled and this will be confirmed by the Owner at the factory acceptance test. Individual wire terminations are required.
9	Cameras and Lighting for remote operation. None are noted in the documents, please confirm this is correct?	Correct.
10	Please confirm that both of the festoon cables will be supplied mounted on their permanent trolleys and loaded onto separate temporary festoon beam for lifting and installation onto the existing festoon rail.	Konecranes response; "Confirmed."
11	Please provide weight of beam and festoon cable noted in question above.	Konecranes response; "Will provide."
12	While the total weight of the bridge is given in the documentation. Please provide, the weight of each girder as shipped - The weight of each end carriage as shipped and the weight of the trolley as shipped.	Konecranes response; "We will provide component weights." We have the following preliminary information from early in the crane supply discussions but these will probably change: Bridge weight 15500 kg Hoist weight 5200 kg Grab weight 3400 kg These are provided only as an order of magnitude.
13	Please confirm that Kone will provide all necessary brackets and hardware for locating and fixing of proximity switches and detectors etc. to the cranes or crane beams for automated control.	Konecranes response; "Yes we will be providing out standard hardware similar to previous crane."
14	Please confirm that the Kone will supply all necessary nuts, bolts, pins, washers and other hardware for the assembly and installation of the cranes and associated walkways, gantries ladders, festoon, proximity switches, e-gates etc.	Konecranes response; "Confirmed."
15	Please confirm that Owner will supply and pay all costs including travel and accommodation for Kone electrician and Kone Commissioning agents.	It is our intention to provide technical assistance during the works, as needed. The Proponent remains in control of the Works but a Konecranes representative will be available for consultation. The cost of the technical assistance will be to the Owners account. The Proponent will assist with coordinating work times to maximize the technical assistance.

16	Please confirm that the existing festoon beam is to be reused. Note Kone Annex H notes supply of festoon beam and brackets is by Customer (Tynes Bay).	The existing W12 steel beam will be reused to support the new festoon cables.
17	Please explain what the I- Beam for power supply is? From the description in Annex H Page 3/6 Item 1 this appears to be different from the festoon beam.	The steel "I" beam that currently supports the existing festoon cables will be re-used for the new festoon cables. The Contractor will be required to inspect the beam and the beam connections to the building to confirm they remain suitable for use. We do not have an I beam that is being used for power supply support other than the festoon support. All other power supplies should be in cable trays or conduit.
18	Please identify in Annex H Page 3/6 Item 4, what "platforms, stairs and gangways" if any in the building are to be supplied by the Contractor.	No platforms, stairs and gangways other than any that are supplied with the cranes are required. The cranes have walkways and handrails to be installed.
19	Where is the E-room referred to in the Annex H Page 3/6 Item 7, and please confirm that there is adequate room for the noted crane electrical cabinet.	Level 4, MCC room. There is adequate room for the noted crane electrical cabinet.
20	Please indicate what, if any interfaces are required between the new cranes and other detectors (input signals) that already exists in the facility. E.g. Annex H Page 3/6 Item 9 refers to feed hopper waste level indicator. If this interface is required this needs to be coordinated and incorporated between Kone and Tynes Bay at design/manufacture time.	There is no interconnection between the feed hopper level indicator and the crane control supplied by the Owner.
21	Same question as above. Refer Annex H Page 3/6 Item 10. Traffic lights, dump gates truck detection	There are no traffic lights, dump gates or truck detection required.
22	Please confirm that the building is watertight as per Kone Buyers Responsibility Annex H Page 5/6, notwithstanding alterations to be carried out by the Contractor to provide access for installation.	The building is suitable to meet our requirements.
23	Note that the tender documentation refers to replacement of any building envelope systems removed for the purposes of installation, with new materials. It is unlikely that matching panels will be easily sourced due to the age of the building. Please provide details of the wall and roof cladding profiles or confirm that removed panels can be reused providing that new fixings, butyl seals etc. are used in refastening.	This requirement might be waived if the panels are removed carefully, not destroyed, and it can be demonstrated that they can be re-installed properly.

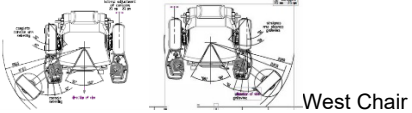
24	Please identify where in the Control room (position and orientation) that the Kone E5 (Master PLC) enclosure is to be installed	The exact location will have to be agreed. The room is tight and the panel is fairly large so the Bidders should expect to relocate an existing panel to make room for this new panel.
25	Please confirm the new chairs will fit in the same location as the existing chairs without modification to mounting structure in the floor, and provide details of the fixing base.	<p>The chairs will fit in the same locations as the existing chairs. The new chair on the west side will be modified, by the supplier, during the factory acceptance testing.</p>  <p>The chair cut sheets are attached.</p>
26	Please confirm that the chairs will direct mount to the floor or if there will be a sliding base for the chairs	Please see the mounting plate shown on the attached cut sheet.
27	Please confirm that the existing crane identified by the plant as “B”, is the north crane and that the replacement north crane is identified by Kone as Crane #1	Yes, the north crane is referred to as Crane B by the Plant and as Crane #1 by Konecranes.
28	Please identify exactly what materials will be provided for the crane rail replacement - ref annex C section 7 and annex H - page 29 - item 15 and Annex D Item 18?	The shop drawings have been requested from Konecranes and will be made available asap.
29	Annex C - Ref 7.5 - Include supply length of each rail and the rail joint connection design / drawing.	98m of rail will be supplied, each side is 49.5m long. The shop drawings have been requested from Konecranes and will be made available asap.
30	Please confirm that the crane rail joints will be supplied scarfed and prepared the accept fishplates etc., for connection.	The shop drawings have been requested from Konecranes and will be made available asap.
31	Annex C - Ref 7.4 - What new rail clip & hardware will be provided - and will materials be provided to replace broken or damaged clips - Drilling holes for through bolting is not an option due to beam design with inverted channel	The shop drawings have been requested from Konecranes and will be made available asap.
32	Do Tynes Bay have any temporary rail stops for the existing rails and can these be made available to the contractor? Are any new temporary rail stops to be supplied with the new rails?	No, Tynes Bay does not have temporary rail stops. The proponent must provide means to prevent the cranes from rolling into work areas as part of the Health and Safety procedures.
33	Annex C - ref sections 9 - Component and System Testing Programme and 10 - System Commissioning Programme. Please confirm that these sections both describe a scope of	The Contractor will be required to assist Konecranes representatives with Section 9 and 10 by supplying skilled labour to make adjustments to the Contractor's installation if needed.

	works to be carried out by Kone Cranes and not by the Contractor?	
34	Annex C - ref 11.2 - It is preferred by the contractor to complete load testing with the grapple disconnected and we will allow for this.	The load test is only for the crane itself not the grapples so they do not have to be attached during the load test.
35	Is there a reliability / proving period required of the first new crane installed before the old south crane can be removed?	Yes. After the first new crane is commissioned and ready to be put into Operations and before the second old crane is removed, a period of approximately one week will be needed to confirm the reliability of the new crane. The Proponent must be ready to assist with repairs or adjustments to the new crane so production can continue.

2. Other Information

- a. A factory acceptance test will be held in the Konecranes Factory in Houston TX, USA. The exact date has not been set but it might be prudent for the successful Proponent to plan to attend the testing to view the assembled equipment. The cost of this visit should be included in the proposal.
- b. Control Chair Cut Sheets

Driver seat KFS 10



The crane driver`s seat KFS 10 is ergonomically designed and provides a high grade of comfort. The driver`s seat has a pneumatic vibration absorption system with weight adjustment by compressor (24V DC 8 Ampere) and a standard seat cushion V-cut. Through its three horizontal adjustment, it can be flexibly adapted to very many applications. All adjustment controls are positioned ergonomically within easy access. The metal parts are protected against corrosion and painted black.

Technical data:

Suspension stroke	80 mm
Weight adjustment	50 - 150 kg (pneumatic) 50 - 130 kg (mechanical)
Horizontal adjustment	
Seat with suspension system	160 mm
Seat part individual	240 mm
Seat cushion	160 mm
Inclination of the backrest	max. 90°
Height and slope adjustment	40 mm



Example

	KFS 102	-A1	-L2	-S2	-R1
Driver seat					
KFS 101	Driver seat with air-permeable artificial leather cover black with V-cut				
KFS 102	Driver seat with textile cover black with V-cut				
Attachments					
K	Headrest				
A1	Armrest adjustable (2 pieces) 50 mm wide				
A2	Armrest continuously adjustable (2 pieces) 100 mm wide				
L1	Lumbar support manual adjustment - 2 movement				
L2	Lumbar support manual adjustment - 4 movement				
B	Seat allocation recognition				
H	Seat cushion and backrest with heating element 24 V DC 47W				
S1	Safety belt 2 point fixing (automatic)				
S2	Safety belt 4 point fixing (headrest required)				
S3	Safety belt 2 point fixing (static)				
U	Console (base)				
C3	Loose cover for driver seat KFS 10 with V-cut				
R1	Price reduction pneumatic vibration absorption system				
R2	Seat cushion without V-cut				

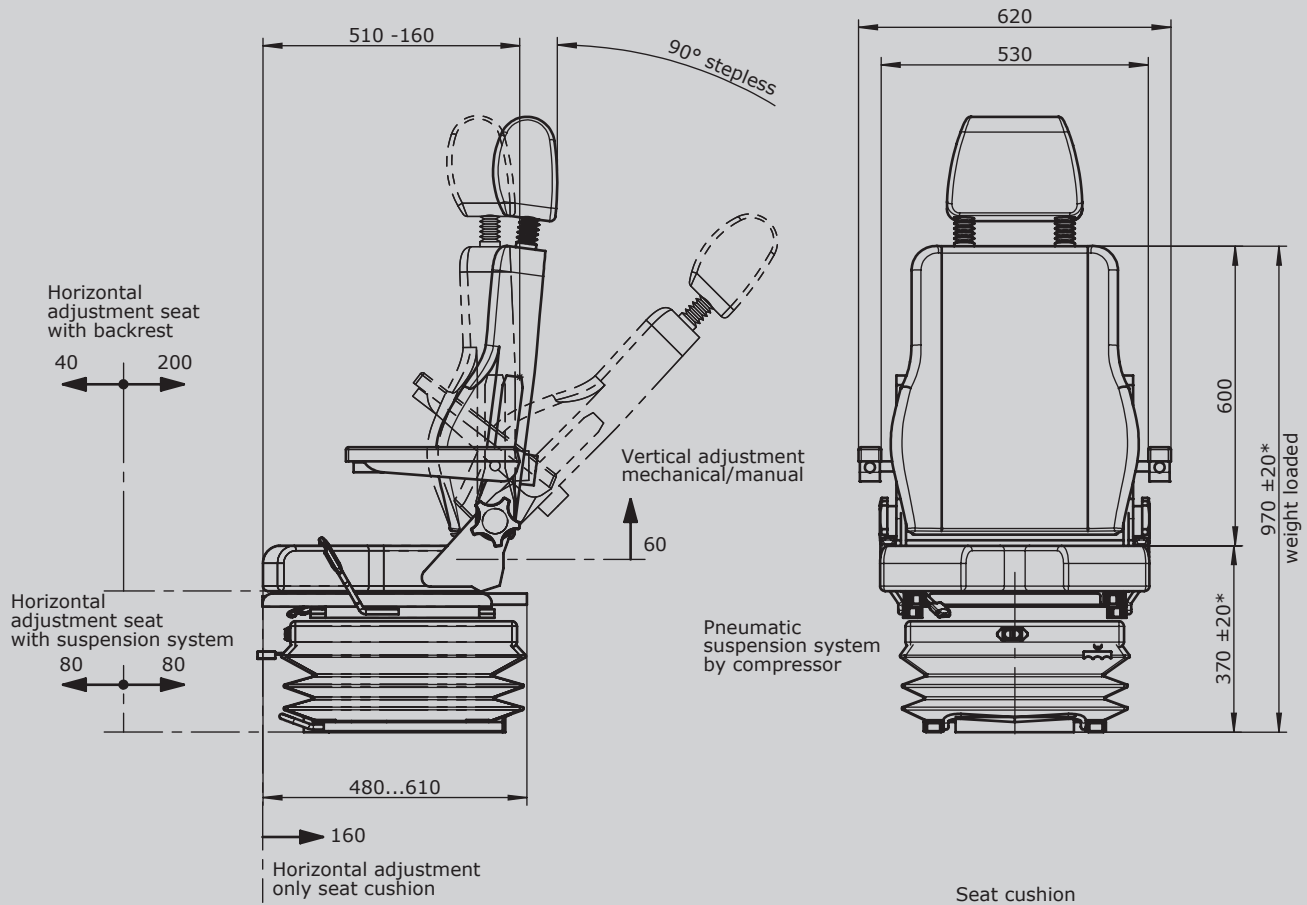

Seat cushion
V-cutout

Mounting dimensions seat

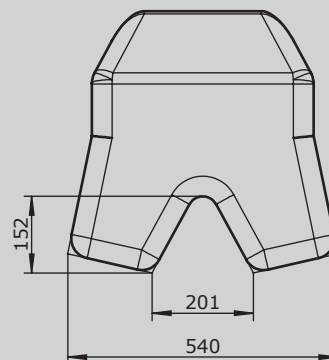
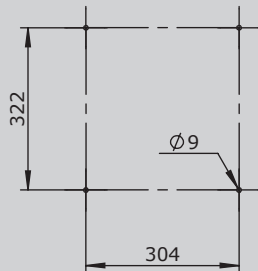

* adjustable

Manuel Swivel with Detent

6040000012

**Dreheinheit KST mit Steckdose
KGSG/84
mit Blindstopfen links, rechts und Rastung**

**Swivelbase KST with socket
KGSG/84
with detend blind plug left, right and detend**

