

ROAD



GENERAL NOTES
 DO NOT SCALE DRAWINGS
 ANY MISSING OR UNCLEAR DIMENSIONS TO BE REPORTED TO CTX FOR CLARIFICATION
 REFER TO STRUCTURAL ENGINEER NOTES FOR ALL DRAWINGS
 REFER TO MECHANICAL ENGINEERING PLANS FOR PLUMBING AND AIR CONDITIONING SYSTEMS INFORMATION
 REFER TO ELECTRICAL ENGINEERING DRAWINGS FOR ELECTRICAL LAYOUT AND SYSTEM INFORMATION
ANY DEVIATION FROM PLANNING APPROVED DOCUMENTS REQUIRES THE SUBMISSION OF A PLANNING REVISION NO EXCEPTIONS

PLANTING

- EXISTING TREE TO BE REMOVED
 - EXISTING TREE (AS SHOWN)
 - GRASS
 - PROPOSED CEDAR TREE
- ALL OTHER VEGETATION SHOWN IS EXISTING AND IS TO REMAIN.

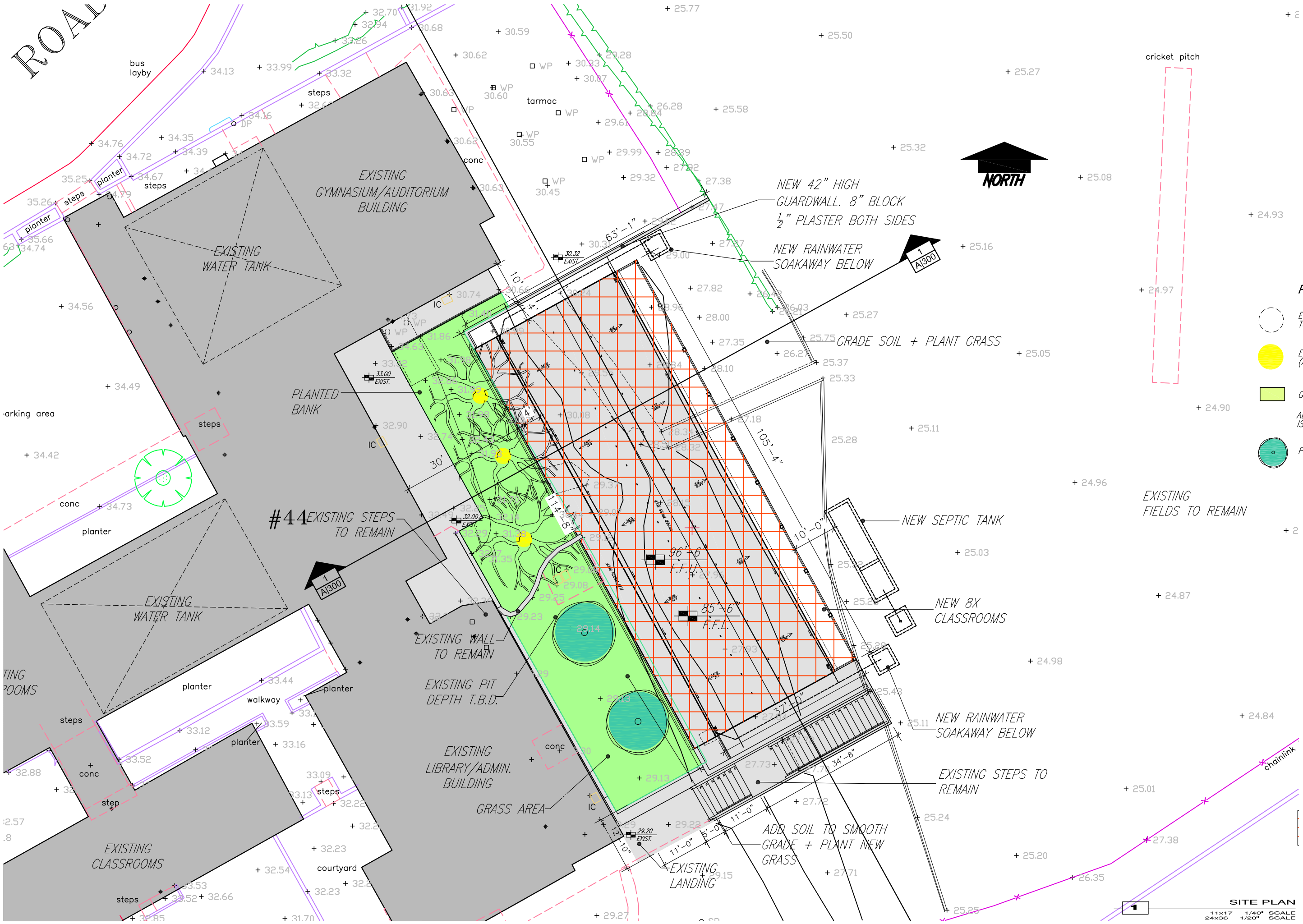

SITE PLAN
 11x17 1/40" SCALE
 24x36 1/20" SCALE

NOV 07 2023

SITE PLAN HAS BEEN PREPARED FROM EXISTING DRAWINGS & NOT A RECENT SURVEY. ALL DIMENSIONS TO BE VERIFIED ON SITE.

REVISIONS

PURVIS PRIMARY

#44 ST. MARY'S ROAD, WARWICK BERMUDA

TECHNICIAN: BMS
 REF: sDs 05449
 DATE: MAR 2023
 SCALE: AS NOTED

A/101

GENERAL NOTES

DO NOT SCALE DRAWINGS
 ANY MISSING OR UNCLEAR DIMENSIONS TO BE REPORTED TO CTX FOR CLARIFICATION
 REFER TO STRUCTURAL ENGINEER NOTES FOR ALL DRAWINGS
 REFER TO MECHANICAL ENGINEERING PLANS FOR PLUMBING AND AIR CONDITIONING SYSTEMS INFORMATION
 REFER TO ELECTRICAL ENGINEERING DRAWINGS FOR ELECTRICAL LAYOUT AND SYSTEM INFORMATION

ANY DEVIATION FROM PLANNING APPROVED DOCUMENTS REQUIRES THE SUBMISSION OF A PLANNING REVISION NO EXCEPTIONS

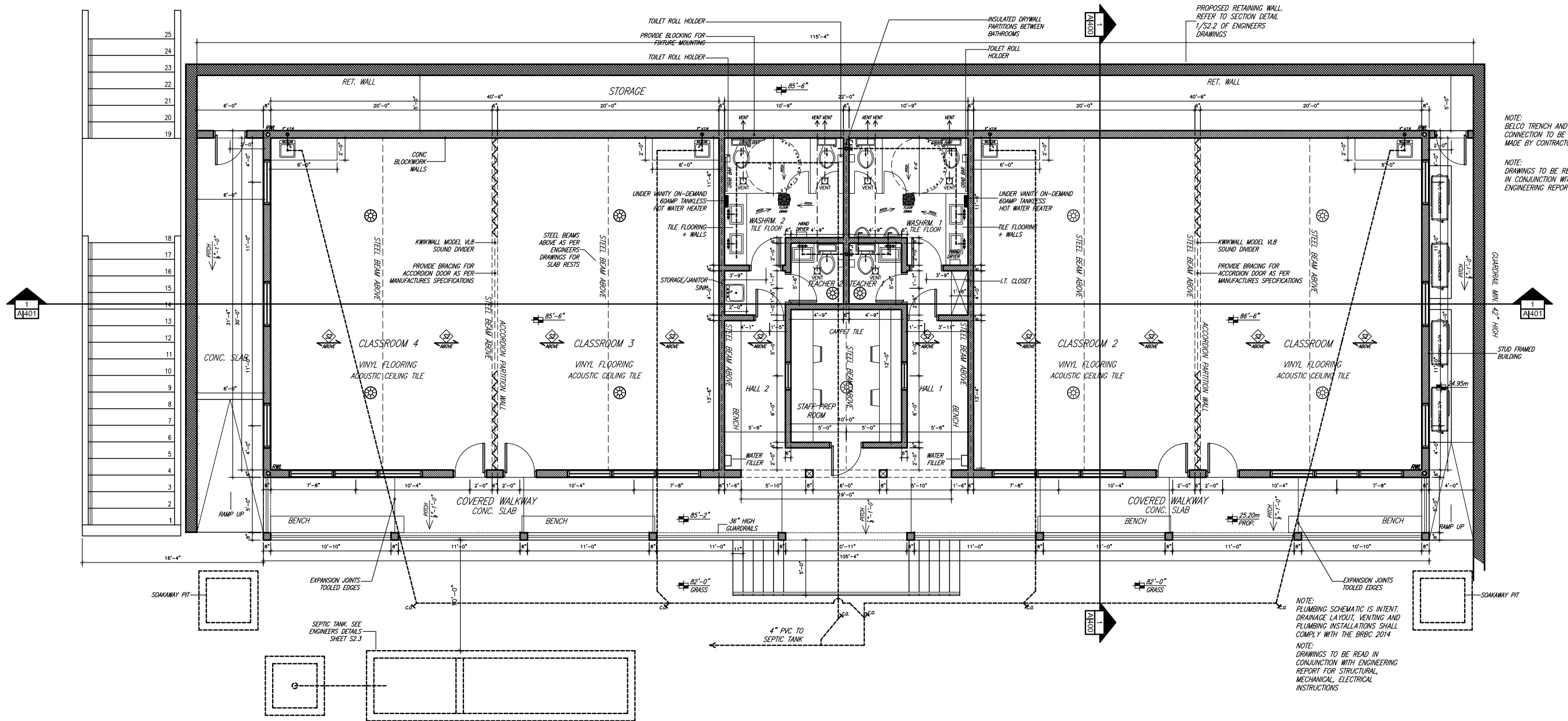

NOV 07 2023

REVISIONS

PURVIS PRIMARY

#44 ST. MARY'S ROAD,
 WARWICK
 BERMUDA

TECHNICIAN:
 BMS
 REF:
 sDs 05449
 DATE:
 MAR 2023
 SCALE:
 AS NOTED

A/201



GENERAL NOTES

DO NOT SCALE DRAWINGS
ANY MISSING OR UNCLEAR DIMENSIONS TO BE REPORTED TO CTX FOR CLARIFICATION
REFER TO STRUCTURAL ENGINEER NOTES FOR ALL DRAWINGS
REFER TO MECHANICAL ENGINEERING PLANS FOR PLUMBING AND AIR CONDITIONING SYSTEMS INFORMATION
REFER TO ELECTRICAL ENGINEERING DRAWINGS FOR ELECTRICAL LAYOUT AND SYSTEM INFORMATION

ANY DEVIATION FROM PLANNING APPROVED DOCUMENTS REQUIRES THE SUBMISSION OF A PLANNING REVISION NO EXCEPTIONS

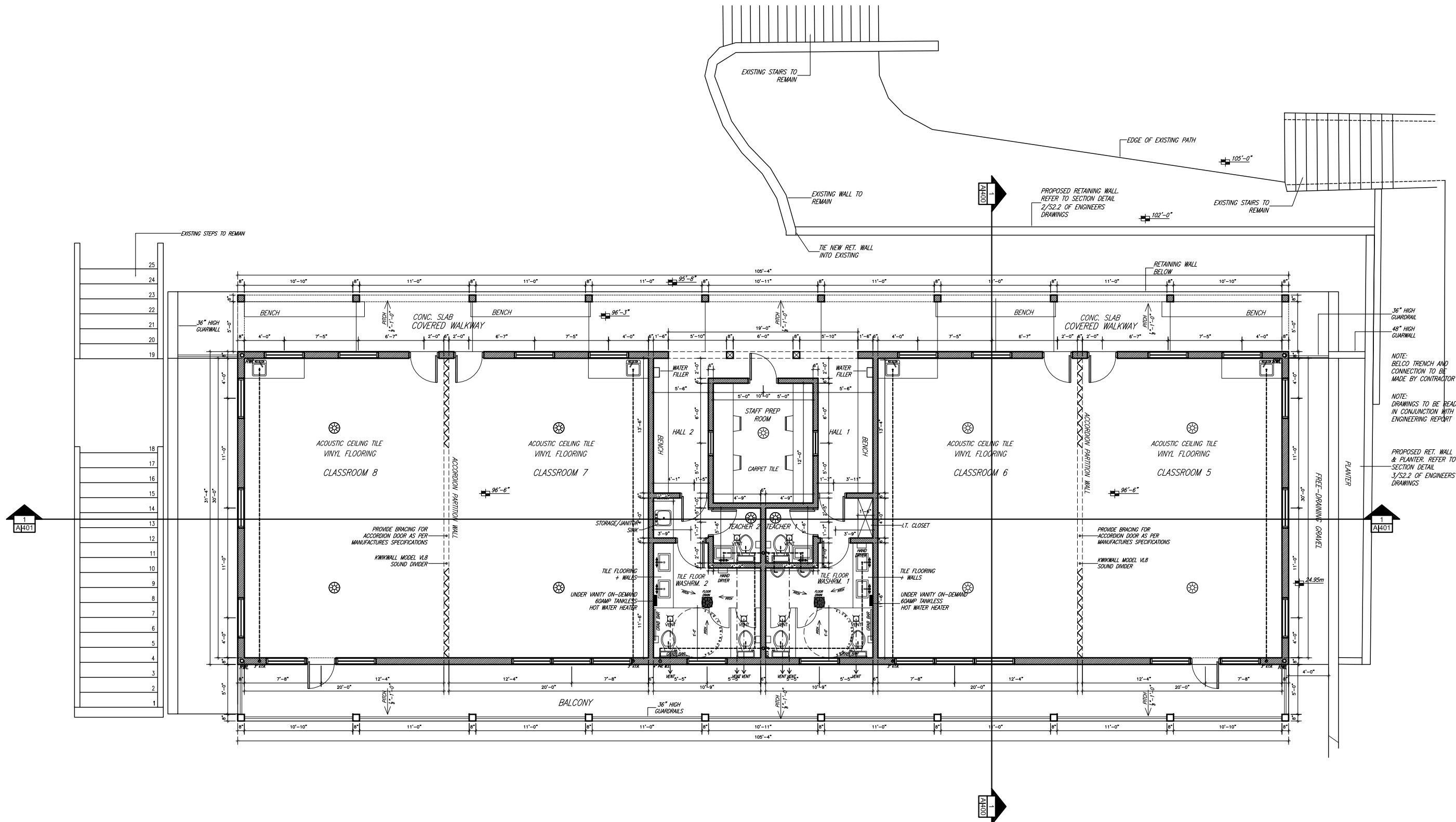

NOV 07 2023

REVISIONS

PURVIS PRIMARY

#44 ST. MARY'S ROAD, WARWICK BERUDA

TECHNICIAN: BMS
REF: sDs 05449
DATE: MAR 2023
SCALE: AS NOTED

A|201a

1 UPPER PLAN
11x17 1/10" SCALE
24x36 1/5" SCALE

GENERAL NOTES

DO NOT SCALE DRAWINGS
 ANY MISSING OR UNCLEAR DIMENSIONS TO BE REPORTED TO CTX FOR CLARIFICATION
 REFER TO STRUCTURAL ENGINEER NOTES FOR ALL DRAWINGS
 REFER TO MECHANICAL ENGINEERING PLANS FOR PLUMBING AND AIR CONDITIONING SYSTEMS INFORMATION
 REFER TO ELECTRICAL ENGINEERING DRAWINGS FOR ELECTRICAL LAYOUT AND SYSTEM INFORMATION

ANY DEVIATION FROM PLANNING APPROVED DOCUMENTS REQUIRES THE SUBMISSION OF A PLANNING REVISION NO EXCEPTIONS

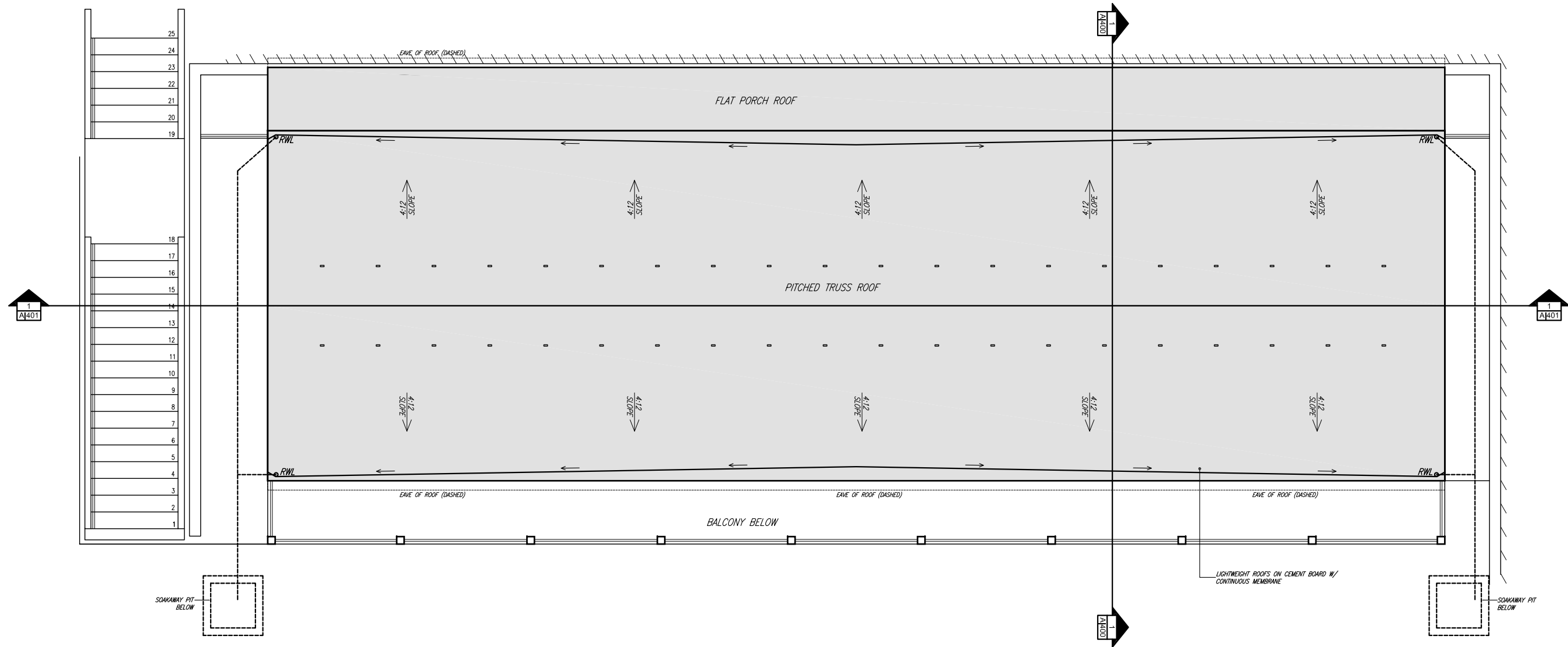

NOV 07 2023

REVISIONS

PURVIS PRIMARY

#44 ST. MARY'S ROAD, WARWICK BERMUDA

TECHNICIAN:
 BMS
 REF:
 sDs 05449
 DATE:
 MAR 2023
 SCALE:
 AS NOTED



GENERAL NOTES

DO NOT SCALE DRAWINGS
ANY MISSING OR UNCLEAR DIMENSIONS TO
BE REPORTED TO CTX FOR CLARIFICATION
REFER TO STRUCTURAL ENGINEER NOTES
FOR ALL DRAWINGS
REFER TO MECHANICAL ENGINEERING
PLANS FOR PLUMBING AND AIR
CONDITIONING SYSTEMS INFORMATION
REFER TO ELECTRICAL ENGINEERING
DRAWINGS FOR ELECTRICAL LAYOUT AND
SYSTEM INFORMATION

ANY DEVIATION FROM
PLANNING APPROVED
DOCUMENTS REQUIRES
THE SUBMISSION OF A
PLANNING REVISION
NO EXCEPTIONS



EAST ELEVATION

11x17 1/10" SCALE
24x36 1/5" SCALE

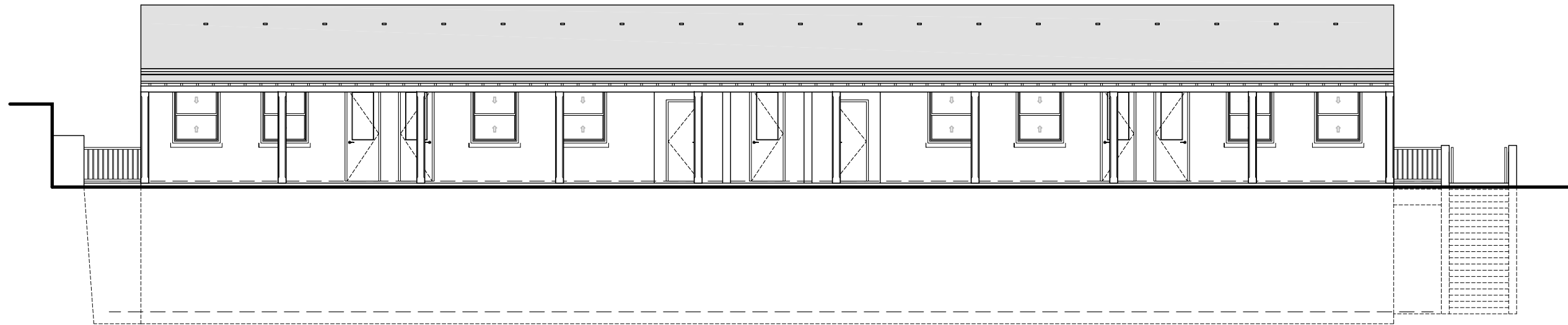

WEST ELEVATION

11x17 1/10" SCALE
24x36 1/5" SCALE

NOV 07 2023

REVISIONS

PURVIS PRIMARY

**#44 ST. MARY'S ROAD,
WARWICK
BERMUDA**

TECHNICIAN:
BMS

REF:
SDs 05449

DATE:
MAR 2023

SCALE:
AS NOTED

A/300



GENERAL NOTES

DO NOT SCALE DRAWINGS
ANY MISSING OR UNCLEAR DIMENSIONS TO
BE REPORTED TO CTX FOR CLARIFICATION
REFER TO STRUCTURAL ENGINEER NOTES
FOR ALL DRAWINGS
REFER TO MECHANICAL ENGINEERING
PLANS FOR PLUMBING AND AIR
CONDITIONING SYSTEMS INFORMATION
REFER TO ELECTRICAL ENGINEERING
DRAWINGS FOR ELECTRICAL LAYOUT AND
SYSTEM INFORMATION

**ANY DEVIATION FROM
PLANNING APPROVED
DOCUMENTS REQUIRES
THE SUBMISSION OF A
PLANNING REVISION
NO EXCEPTIONS**

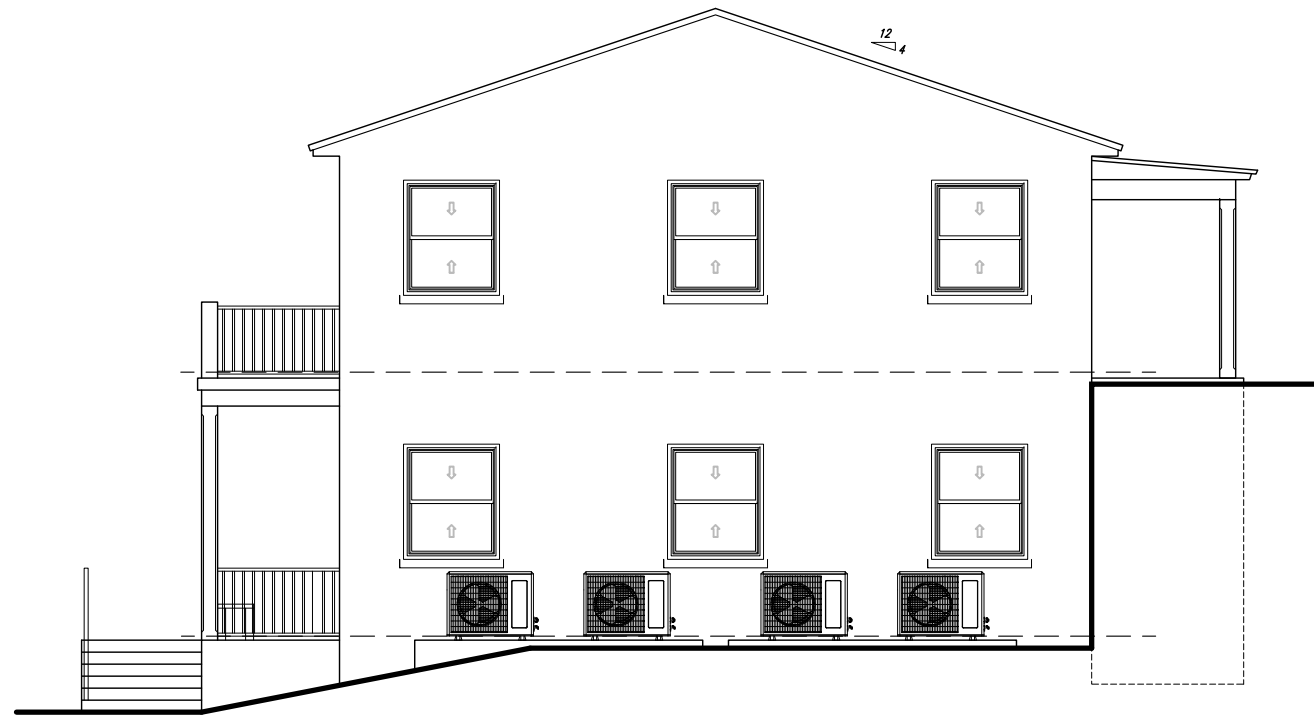

1 NORTH ELEVATION
11x17 1/8" SCALE
24x36 1/4" SCALE

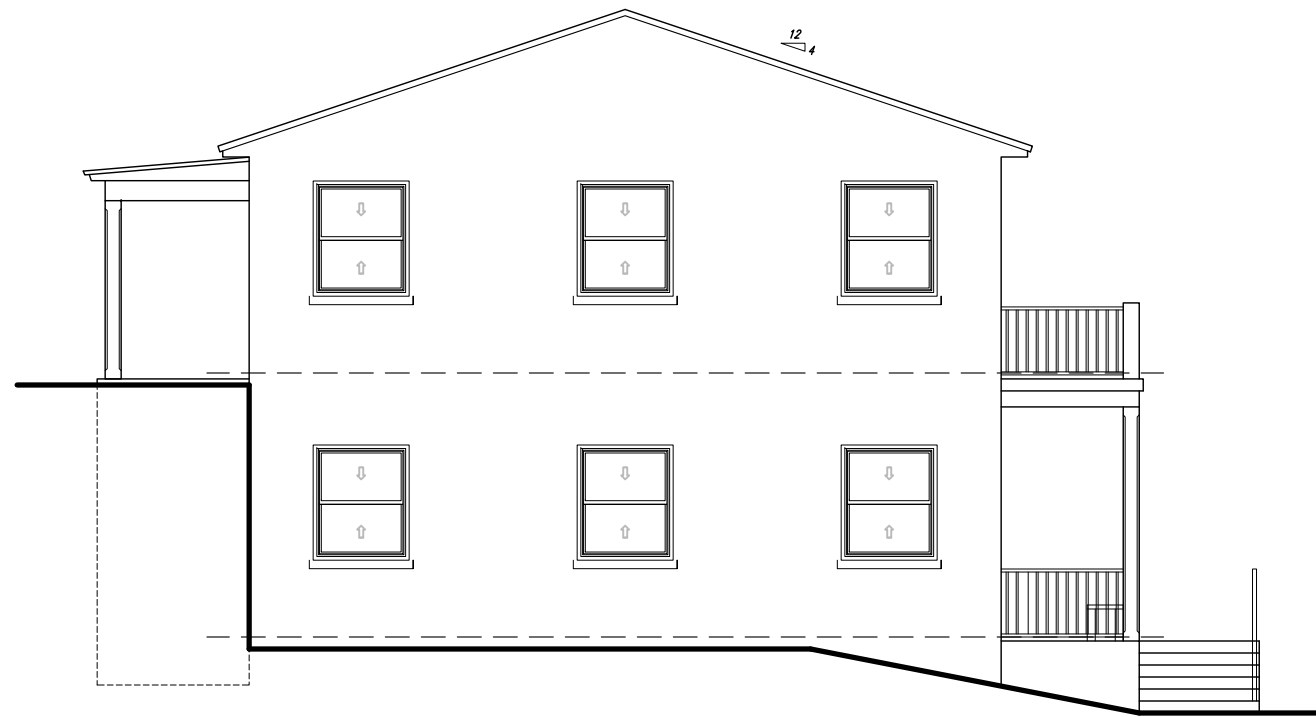

2 SOUTH ELEVATION
11x17 1/8" SCALE
24x36 1/4" SCALE

NOV 07 2023

REVISIONS

PURVIS PRIMARY

**#44 ST. MARY'S ROAD,
WARWICK
BERMUDA**

TECHNICIAN:
BMS

REF:
SDs 05449

DATE:
MAR 2023

SCALE:
AS NOTED

A/301

GENERAL NOTES

DO NOT SCALE DRAWINGS
 ANY MISSING OR UNCLEAR DIMENSIONS TO BE REPORTED TO CTX FOR CLARIFICATION
 REFER TO STRUCTURAL ENGINEER NOTES FOR ALL DRAWINGS
 REFER TO MECHANICAL ENGINEERING PLANS FOR PLUMBING AND AIR CONDITIONING SYSTEMS INFORMATION
 REFER TO ELECTRICAL ENGINEERING DRAWINGS FOR ELECTRICAL LAYOUT AND SYSTEM INFORMATION

ANY DEVIATION FROM PLANNING APPROVED DOCUMENTS REQUIRES THE SUBMISSION OF A PLANNING REVISION NO EXCEPTIONS

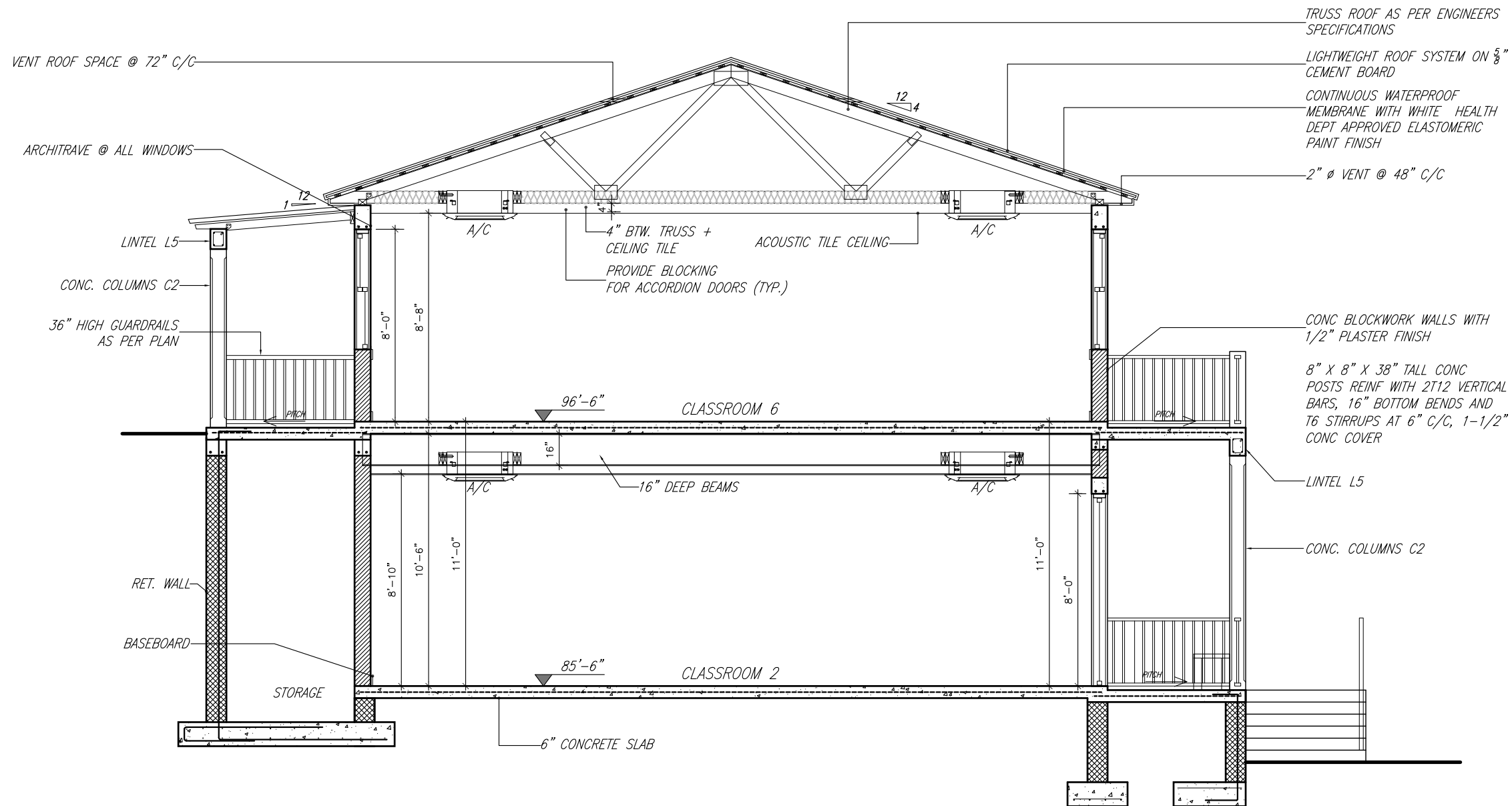

1 BUILDING SECTION 1
 11x17 3/16" SCALE
 24x36 3/8" SCALE

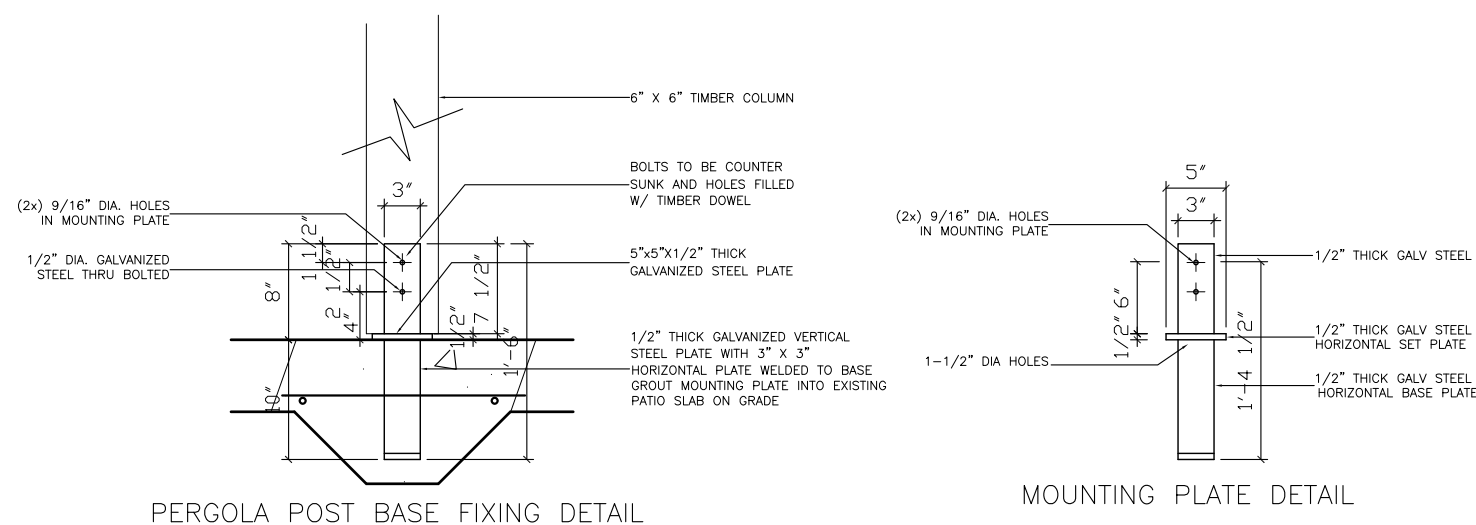

PERGOLA POST BASE FIXING DETAIL

MOUNTING PLATE DETAIL

2 COLUMN CONNECTION DETAILS
 11x17 3/4" SCALE
 24x36 1-1/2" SCALE

NOV 07 2023

REVISIONS

PURVIS PRIMARY

#44 ST. MARY'S ROAD, WARWICK, BERMUDA

TECHNICIAN:

BMS

REF:

sDs 05449

DATE:

MAR 2023

SCALE:

AS NOTED

A/400

BACKFILL MATERIAL

- BACKFILL MATERIAL SHALL BE FREE FROM ORGANIC MATTER, CONSTRUCTION DEBRIS AND LARGE ROCKS (GREATER THAN 3"(THREE INCHES)). THE BACKFILL SHALL BE PLACED IN LAYERS, NOT GREATER THAN 8" (EIGHT INCHES), WATERED AND COMPACTED.
- DO NOT BACKFILL AGAINST WALLS RETAINING EARTH UNTIL ELEMENTS PROVIDING LATERAL SUPPORT ARE COMPLETED. PLACE BACKFILL SIMULTANEOUSLY ON BOTH SIDES OF OTHER WALLS BELOW GRADE.

DEMOLITION, EXCAVATION AND EARTHWORK

- REMOVE EXISTING CONSTRUCTION AS INDICATED ON THE DRAWINGS. TAKE NECESSARY PRECAUTIONS TO SUPPORT THE STRUCTURE THAT IS TO REMAIN AND DISPOSE PROMPTLY OF MATERIALS FROM DEMOLITION OPERATIONS. ALL DEBRIS SHALL BE DISPOSED OF AT LEGAL DUMPSITES.
- CARE SHALL BE TAKEN DURING DEMOLITION OF THE EXISTING BUILDING SO AS NOT TO UNLAWFULLY DISTURB ANY PART OF THE EXISTING STRUCTURE THAT IS TO REMAIN.
- WHERE REQUIRED, THE CONTRACTOR SHALL SUBMIT WRITTEN PROPOSALS ON HOW THEY INTEND TO SUPPORT AN EXISTING BUILDING DURING CONSTRUCTION PRIOR TO THE COMMENCEMENT OF WORKS.
- ALL ROCK CUTS GREATER THAN 6' (SIX FEET) IN HEIGHT SHALL BE CERTIFIED BY A REGISTERED STRUCTURAL ENGINEER.
- BACKFILL MATERIAL SHALL BE FREE FROM ORGANIC MATTER, CONSTRUCTION DEBRIS AND LARGE ROCKS (GREATER THAN 3"(THREE INCHES)). THE BACKFILL SHALL BE PLACED IN LAYERS, NOT GREATER THAN 6" (SIX INCHES), WATERED AND COMPACTED.
- DO NOT BACKFILL AGAINST WALLS RETAINING EARTH UNTIL ELEMENTS PROVIDING LATERAL SUPPORT ARE COMPLETED. PLACE BACKFILL SIMULTANEOUSLY ON BOTH SIDES OF OTHER WALLS BELOW GRADE.

FOUNDATIONS

- ALL FOOTING AND FOUNDATIONS TO BEAR ON UNDISTURBED SOUND ROCK. BEARING MATERIAL IS TO REMAIN UNDISTURBED AND BE REVIEWED BY THE ENGINEER PRIOR TO PLACING CONCRETE FOR FOOTING AND FOUNDATIONS. WHERE THE PRESENCE OF ROCK IS EXPECTED BUT NOT DETECTED, THE STRUCTURAL ENGINEER SHALL BE RETAINED TO PROVIDE ALTERNATIVE DETAILS.
- PROVIDE 2" CONCRETE BLINDING TO FOUNDATIONS PLACED ON COMPACTED SAND.
- ALL SHORING, SHEETING, AND DEWATERING SHALL BE THE RESPONSIBILITY OF THE CONTRACTOR.
- THE CONTRACTOR SHALL TAKE PRECAUTIONS TO PROTECT ALL EXISTING STRUCTURES, CURBS, STREETS ETC. FROM DAMAGE BY CONSTRUCTION EQUIPMENT.
- THE CONTRACTOR SHALL NOT DISPOSE OF ANY LIQUIDS, SLURRY, SPOILS OR CHEMICALS ON SITE EXCEPT AS DIRECTED BY THE OWNERS REPRESENTATIVE AND APPROVED BY THE DEPARTMENT OF ENVIRONMENT OR OTHER AGENCIES HAVING JURISDICTION.

CONCRETE

- EXPERIENCED PERSONNEL TO THE SATISFACTION OF THE ENGINEER SHALL MECHANICALLY VIBRATE ALL STRUCTURAL CONCRETE IN THE APPROVED MANNER. THE CONTRACTOR SHALL HAVE AT LEAST TWO FULLY OPERATIONAL POKER VIBRATORS ON SITE DURING CONCRETE PLACEMENT.
- NO SPLICES OF REINFORCEMENT SHALL BE PERMITTED EXCEPT AS DETAILED OR AUTHORIZED BY THE STRUCTURAL ENGINEER. MAKE BARS CONTINUOUS AROUND CORNERS. WHEN PERMITTED, SPLICES SHALL BE MADE BY CONTACT TENSION LAP SPLICES, UNLESS OTHERWISE NOTED.
- WHEN INSTALLING EXPANSION BOLTS OR ADHESIVE ANCHORS, TAKE MEASURES TO AVOID DRILLING OR CUTTING OF ANY EXISTING REINFORCING AND DESTRUCTION OF CONCRETE. HOLES SHALL BE BLOWN CLEAR PRIOR TO PLACING BOLTS OR ADHESIVE ANCHORS.
- CONCRETE SLABS SHALL BE FINISHED FLAT AND LEVEL WITHIN TOLERANCE TO THE ELEVATION INDICATED ON THE DRAWINGS. CONTRACTOR SHALL PROVIDE ADDITIONAL CONCRETE REQUIRED DUE TO FORMWORK AND FRAMING DEFLECTION TO ACHIEVE THIS TOP OF SLAB ELEVATION.
- SLABS SHALL NOT HAVE JOINTS IN A HORIZONTAL PLANE UNLESS SHOWN OTHERWISE.
- ALL CONCRETE WORK SHALL CONFORM TO ACI 301 (LATEST EDITION), SPECIFICATION FOR STRUCTURAL CONCRETE FOR BUILDINGS OR APPROVED EQUIVALENT STANDARD.
- CONCRETE SHALL BE MECHANICALLY COMPACTED IN AN APPROVED MANNER.
- CEMENT: ASTM C150; TYPE I - CAN3-A23.1, TYPE 10
- AGGREGATES: ASTM C33 NORMAL WEIGHT.
- STRUCTURAL CONCRETE SHALL ACHIEVE A MINIMUM CUBE COMPRESSIVE STRENGTH AT 28 DAYS AS FOLLOWS UNLESS NOTED OTHERWISE.
 - FOOTINGS = 4,000 PSI
 - SLABS ON GRADE = 4,000 PSI
 - SUSPENDED SLABS = 4,500 PSI
 - RETAINING WALLS = 3,000 PSI
 - MISCELLANEOUS FILL = 2,000 PSI
- CONCRETE COVER TO BARS SHALL BE AS FOLLOWS, UNLESS NOTED OTHERWISE:
 - 3" FOR CONCRETE CAST AGAINST AND PERMANENTLY EXPOSED TO EARTH. FOUNDATIONS, RETAINING WALLS.
 - 2" FOR CONCRETE EXPOSED TO WEATHER.
 - 1/2" FOR CONCRETE NOT EXPOSED TO WEATHER OR IN CONTACT WITH GROUND. SLABS, WALLS, BEAMS, COLUMNS.

REINFORCING STEEL

- ALL STEEL BARS SHALL BE GALVANIZED WITH A MINIMUM YIELD STRESS OF 60,000 PSI UNLESS NOTED OTHERWISE.
- UNLESS NOTED OTHERWISE, MINIMUM ALLOWABLE LAP LENGTHS TO REBAR SHALL BE:
 - T6 = 12" (TWELVE INCHES)
 - T8 = 15" (FIFTEEN INCHES)
 - T10 = 18" (EIGHTEEN INCHES)
 - T12 = 24" (TWENTY FOUR INCHES)
 - T16 = 32" (THIRTY TWO INCHES)
 - T20 = 40" (FORTY INCHES)
 - T25 = 60" (SIXTY INCHES)
 - WIRE MESH = 12" (TWELVE INCHES)

- LOCATION OF ALL LAPS SHALL BE SHOWN ON REINFORCEMENT STEEL SHOP DRAWINGS AND SHALL BE APPROVED BY THE STRUCTURAL ENGINEER.
- REBAR SHALL CONFORM TO ASTM-767 GRADE 60 GALV. WELDED WIRE FABRIC (MESH) SHALL CONFORM TO ASTM-A-185.

MASONRY WALLS

- THE AVERAGE COMPRESSIVE STRENGTH OF MASONRY UNITS SHALL BE 2000 PSI BASED ON THE NET AREA OF THE BLOCK CELL. MASONRY UNITS SHALL CONFORM TO ASTM C90. ALL BLOCKWORK SHALL BE LAYED IN RUNNING BOND U.N.O.
- MORTAR FOR MASONRY SHALL BE "TYPE S" IN ACCORDANCE WITH ASTM C270.
- GROUT FOR MASONRY UNITS SHALL BE 3000 PSI CONCRETE WITH AN 8" SLUMP.
- FILLED BLOCK WALLS SHALL BE CONSTRUCTED IN A MAXIMUM OF FIVE COURSE LIFTS. CONCRETE TO BE STOPPED 2" FROM THE TOP OF THE BLOCK TO ALLOW THE NEXT LIFT TO KEY TOGETHER. REINFORCING BARS ARE TO EXTEND A MINIMUM LAP LENGTH ABOVE THE TOP OF THE POUR.
- ALL OPENINGS IN MASONRY WALLS ARE TO BE SPANNED BY REINFORCED CONCRETE LINTELS.
- MINIMUM BEARING OF REINFORCED CONCRETE LINTELS AND BEAMS ONTO BLOCK WALLS SHALL BE 8" U.N.O.
- ALL LAP SPLICES IN BLOCKWORK REINFORCING SHALL BE AS NOTED IN REINFORCING STEEL NOTES.
- MINIMUM BEARING OF REINFORCED CONCRETE LINTELS AND BEAMS ONTO BLOCK WALLS SHALL BE 8" U.N.O.
- UNLESS NOTED OTHERWISE ALL MASONRY WALLS REQUIRING REINFORCEMENT TO CONSIST OF EITHER:
 - A) 2-16 BARS @ 16" C/C OR EVERY SECOND COURSE WITH 1/2" MIN. COVER FROM THE OUTSIDE OF THE BLOCKS.
 - B) "BUR-0-WALL" TRUSS TYPE REINFORCING NUMBER 9 GAUGE, GALVANIZED WIRE (OR EQUIVALENT BRICK FORCE MESH). HORIZONTAL REINFORCING IS TO BE PLACED AT 16" C/C (EVERY SECOND COURSE) U.N.O.

- ALL WALLS ARE TO RECEIVE A BOND BEAM ON TOP AT FLOOR LEVEL. BOND BEAMS ARE TO BE WIDTH OF WALL WIDE x 8" DEEP REINFORCED WITH 2T12 BARS CONTINUOUS. BOND BEAM REINFORCING IS TO BE EXTENDED INTO AND BE CONTINUOUS WITH ALL INTERSECTING BOND BEAMS. WHERE BOND BEAMS BUTT UP TO STEEL COLUMNS OR BEAMS, 6"x6"x5/16" ANGLE x 6" LONG IS TO BE WELDED TO THE STEEL MEMBER AND ENCASED IN THE BEAM.
- CONCRETE LINTEL BEAMS (3000 PSI) SHALL BE PROVIDED TO ALL OPENINGS IN ACCORDANCE WITH THE STRUCTURAL SCHEDULE.
- MINIMUM BEARING OF LINTEL BEAMS SHALL BE 12" (TWELVE INCHES), UNLESS NOTED OTHERWISE.
- WHERE THE LINTEL BUTTS UP TO A STEEL COLUMN, A 6" x 6" x 5/16" ANGLE x 6" LONG SHALL BE WELDED TO THE COLUMN WITH 1/4" FILLET WELD ALL AROUND IN ORDER TO PROVIDE A SHELF TO SUPPORT THE LINTEL.

LINTELS

- CONCRETE LINTEL BEAMS (3000 PSI) SHALL BE PROVIDED TO ALL OPENINGS IN ACCORDANCE WITH THE STRUCTURAL SCHEDULE.
- MINIMUM BEARING OF LINTEL BEAMS SHALL BE 12" (TWELVE INCHES), UNLESS NOTED OTHERWISE.
- WHERE THE LINTEL BUTTS UP TO A STEEL COLUMN, A 6" x 6" x 5/16" ANGLE x 6" LONG SHALL BE WELDED TO THE COLUMN WITH 1/4" FILLET WELD ALL AROUND IN ORDER TO PROVIDE A SHELF TO SUPPORT THE LINTEL.

INSPECTION AND TESTING

- CONTRACTOR TO PROVIDE 24 HOURS NOTICE FOR THE INSPECTION OF ALL REINFORCEMENT, INCLUDING MASONRY REINFORCEMENT PRIOR TO PLACING CONCRETE.
- CONCRETE TO BE TESTED BASED ON SPECIFICATION REQUIREMENTS. TESTING TO BE DONE BY AN APPROVED TESTING AGENCY.

DESIGN NOTES:

- DESIGN CODES: STRUCTURAL DESIGN IS IN ACCORDANCE WITH BERMUDA BUILDING CODE 1998, WHICH REFERENCES THE BOCA NATIONAL BUILDING CODE.
- DESIGN DATA:
 - GRAVITY LIVE LOADS
 - ROOF: 30 PSF
 - TYPICAL FLOOR: 85 PSF
 - STAIRS: 100 PSF
 - BALCONY: 60 PSF
 - LATERAL LOADS - WIND (PER ASCE 7.05)
 - BASIC WIND SPEED (3 SEC GUST): 150 MPH
 - EXPOSURE: C
 - IMPORTANCE FACTOR (I): 1.15

WALL SCHEDULE

TYPE	DETAILS
W1	10" HOLLOW CONCRETE BLOCK WALL
W2	10" THK BLOCK FOUNDATION WALL FILLED WITH 3000 PSI CONCRETE
W3	8" THK HOLLOW CONCRETE BLOCK WALL
W4	12" THK BLOCK WALL FILLED WITH 3000 PSI CONCRETE AND REINFORCED WITH T16 @ 16" c/c VERTICAL REBARS BENT 16" MIN INTO SLAB ABOVE AND FOOTING BELOW AND 2-16 @ 16" c/c HORIZONTAL BARS (MIDDLE OF WALL)

WALL NOTES

- BLOCKWORK WALLS THAT ARE BELOW GRADE AND CELLS THAT ARE REINFORCED ARE TO BE SOLID FILLED WITH 3000psi CONCRETE. CELLS ARE TO BE CLEANED OUT PRIOR TO FILLING.
- CONCRETE FILL TO BE PLACED IN MAXIMUM OF 4'-0" HIGH LIFTS WITH THE POUR STOPPING 2" BELOW THE TOP OF THE BLOCK CELL TO ALLOW THE NEXT LIFT TO KEY TOGETHER. REINFORCING BARS ARE TO EXTEND A MINIMUM LAP LENGTH ABOVE THE TOP OF THE POUR.
- CONCRETE WALLS TO BE PLACED IN CONTINUOUS OPERATIONS TO AVOID COLD JOINTS.

FOUNDATION SCHEDULE

TYPE	DETAILS
SF-1	2'-0" WIDE x 12" DEEP CONCRETE STRIP FOOTING REINFORCED WITH 3-T12 LONGITUDINAL REBARS AND T12 @ 12" % TRANSVERSE REBARS (3" CONCRETE COVER).
SF-2	2'-6" WIDE x 12" DEEP CONCRETE STRIP FOOTING REINFORCED WITH 3-T12 LONGITUDINAL REBARS AND T12 @ 12" % TRANSVERSE REBARS (3" CONCRETE COVER).

FOUNDATION NOTES

- ALL FOUNDATION TO BEAR ON UNDISTURBED BEDROCK. CONTACT REGISTERED ENGINEER IF CONDITIONS ARE DIFFERENT.
- TAKE FOOTINGS DOWN TO BEDROCK AND THEN CONSTRUCT BACK UP TO UNDERSIDE OF SLAB LEVEL WITH SOLID FILLED BLOCKWORK WALLS.
- CAST STARTER BARS INTO FOOTINGS TO MATCH VERTICAL WALL OR COLUMN STEEL, 12" HORIZONTAL LEGS, VERTICAL LEG LENGTH AS NECESSARY TO MEET MINIMUM LAP LENGTH AS PER TABLE.
- COVER TO FOOTING STEEL TO BE 3"
- AT ALL INTERSECTIONS AND CORNERS OF FOOTINGS, INSTALL 2-T16 "L" BARS WITH 36" LEGS

SLAB SCHEDULE

TYPE	DETAILS
S1	6" THK. SLAB ON GRADE ON 6 MIL POLY ON WELL COMPACTED SUB-GRADE REINFORCED w/ A142 MESH (1/2" FROM TOP).
S2	6" SLAB ON "20G" METAL DECK REINFORCED WITH A-142 MESH (1.5" FROM TOP) AND T12 @ 8" x 5'-0" LONG BARS (1.5" FROM TOP) CENTERED ABOVE STEEL BEAMS (TYP).
S3	6" SLAB PLY-FORMED SUSPENDED SLAB REINFORCED WITH T12@8" C/C (BTM) IN THE SHORT SPAN OF SLAB AND T12@12 C/C TRANSVERSE BARS (BTM). ALSO REINFORCE WITH A-142 MESH (1.5" FROM TOP)

SLAB NOTES

- CONSTRUCTION JOINTS IN SLABS TO BE KEPT TO A MINIMUM AND WHERE NECESSARY BE CENTERED OVER BEAMS AND ARE TO BE SQUARE AND VERTICAL. REINFORCEMENT TO BE CONTINUED THROUGH JOINTS A MINIMUM LAP LENGTH.
- SLABS ARE TO BE CURED FOR A MINIMUM OF 7 DAYS BY KEEPING CONTINUOUSLY MOIST.
- SLABS AND REINFORCING TO BEAR A MINIMUM OF 4" ONTO NEW BEAMS, 4" ONTO BLOCKWORK WALLS, OR 6" ONTO BERMUDA STONE WALLS.
- EXTERIOR SLABS TO BE LAID TO FALLS AWAY FROM BUILDING WITH A MINIMUM SLOPE OF 2% . THICKNESS SHOWN IN TABLES IS MINIMUM DEPTH OF SLAB. INCREASE AS NECESSARY TO ACHIEVE THE DESIRED FALLS.

CONCRETE LINTEL SCHEDULE

TYPE	SPAN	W x D	REINFORCEMENT	TIES
L-1	SEE PLAN	"wow" x 10"	2-T12 (BTM)	-
L-2	SEE PLAN	10" x 10"	2-T16 (BTM)	-
L-3	SEE PLAN	10" x 24"	2-T16 (TOP) & 4-T20 (BTM)	T10 @ 8" C/C
L-4	SEE PLAN	10" x 24"	2-T16 (TOP) & 2-T20 (BTM)	T10 @ 12" C/C
L-5	SEE PLAN	8" x 10"	2-T12 (TOP) & 2-T12 (BTM)	T18 @ 10" C/C
BB-1	CONT.	10" x 14"	2-T16 (TOP) & 2-T16 (BTM)	-

LINTEL NOTES

- * TYPICAL LINTELS WHERE NOT OTHERWISE INDICATED.
- ALL LINTEL TYPES SHOWN INDICATE LINTEL ABOVE FLOOR LEVEL.
- ENSURE THAT EXISTING WALLS, FLOORS, AND ROOFS ARE SECURELY PROPPED PRIOR TO DEMOLITION OPERATIONS AND INSTALLATION OF BEAMS.
- ABBREVIATIONS: NOI: NOT OTHERWISE INDICATED, WOW: WIDTH OF WALL IN WIDTH, UNO: UNLESS NOTED OTHERWISE
- CONCRETE BEAMS AND LINTELS ARE TO HAVE A MAXIMUM OF 8" BEARING EITHER SIDE. REINFORCING IS TO CONTINUE A MINIMUM OF 6" OVER SUPPORTS. AT CORNERS AND INTERSECTIONS, HOOK BARS 36".
- BLOCK CELLS BELOW EACH END OF BEAMS AND LINTELS ARE TO BE SOLID FILLED DOWN TO SLAB LEVEL.
- WHEN POURING BELT BEAM, ALLOW CONCRETE TO EXTEND A MINIMUM OF 4" DOWN INTO BLOCK CELLS BELOW.

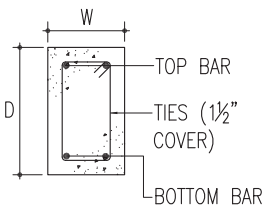

CONCRETE STAIR SCHEDULE

TYPE	DETAILS
SS1	6" THICK MIN. WAIST. WIDTH AS NOTED ON ARCHITECTURAL DRAWINGS. REINFORCE WITH T12 @ 6" % BARS IN BOTH DIRECTIONS OF SLAB (1/2" FROM BOTTOM).

STAIR NOTES

- CONCRETE STAIRS ARE TO BE CURED FOR A MINIMUM OF 7 DAYS BY KEEPING CONTINUOUSLY MOIST
- STAIRS, LANDING SLABS AND REINFORCING TO BEAR A MINIMUM OF 4" ONTO WALLS AND BEAMS
- CONTINUE STAIR REINFORCING THROUGH LANDING SLABS

WALL STIFFNER SCHEDULE

TYPE	SIZE	REINFORCEMENT	TIES
WS-1	8" x 16"	2-T12 (VERT. BARS)	T6 @ 16" CTS.

WALL STIFFNER NOTES

- ALL VERTICAL BARS TO HAVE 12" BEND INTO SLAB OR BEAM ABOVE AND SLAB/FOUNDATION BELOW.
- BLOCKWORK COLUMNS TO BE POURED IN MAXIMUM 4' HIGH LIFTS WITH THE POUR STOPPING 2" BELOW THE TOP OF THE BLOCK CELL TO ALLOW THE NEXT LIFT TO KEY TOGETHER. REINFORCING BARS ARE TO EXTEND A MINIMUM LAP LENGTH ABOVE THE TOP OF THE POUR.

COLUMN SCHEDULE

TYPE	SIZE	REINFORCEMENT	TIES
C-1	10" x 10"	4-T16 (VERT. BARS)	T8 @ 8" CTS.
C-2	8" x 8"	4-T16 (VERT. BARS)	T8 @ 8" CTS.

COLUMN NOTES

- ALL VERTICAL BARS IN COLUMNS TO HAVE 12" BEND INTO SLAB/BEAM ABOVE AND SLAB/FOUNDATION BELOW.
- CONCRETE COLUMNS ARE TO BE POURED FULL HEIGHT WITHOUT CONSTRUCTION JOINTS.
- CAST STARTER BARS TO MATCH COLUMN REINFORCING INTO SLABS BELOW.

ROOF FRAMING SCHEDULE FOR SKB ROOF

Type	Max. Span	Rafter Size and Spacing	Collar Tie Size and Spacing	Collar Tie Height 'X'	Rafter Connection
R-1	31'-0"	SEE SECTION 5/S2.1			3/4" DIA.
R-2	5'-6"	2"x4" @ 16" C/C			

ROOF NOTES:

- ALL ROOF PITCHES ARE TO MATCH EXISTING 7:12 SLOPE UNLESS STATED OTHERWISE.
- SKB LAPPED PROFILE LIGHTWEIGHT ROOF SYSTEM, ON 5/8" PLYCEN BOARD FIXED DOWN TO RAFTERS WITH #12 x 2 1/2 LONG STAINLESS STEEL SCREWS @ 8" C/C EACH WAY. JOINTS BETWEEN BOARDS TO BE SEALED TO PROVIDE A SECONDARY WATER BARRIER.
- TIMBER CONSTRUCTION SHALL CONFORM TO AITC. NATIONAL DESIGN SPECIFICATIONS AND BERMUDA BUILDING CODE (LATEST EDITION). TIMBER TO BE TYPE "STRUCTURAL LIGHT FRAMING, No. 2" SOUTHERN YELLOW PINE (PITCH PINE).
- ALL TIMBER TO BE WOLMANIZED TYPE, PRESSURE TREATED.
- ALL STEEL NUTS, BOLTS AND WASHERS ARE TO BE HOT DIP GALVANIZED CONFORMING TO ASTM A-325. BOLT HOLES SHALL BE NO LARGER THAN 1/8" GREATER THAN THE NOMINAL BOLT SIZE. ALL BOLTED JOINTS SHALL HAVE WASHERS FITTED UNDER THE HEAD OF THE BOLT AND UNDER EACH NUT. THE SIZE OF THE WASHERS SHALL BE FOR 1/2" BOLTS AND UNDER: 2" DIAMETER x 1/8" THICK; AND, FOR 3/4" BOLTS: 2 1/2" DIAMETER x 1/8" THICK.
- WALL PLATE 3"x4"
- HIP RAFTERS: UNLESS OTHERWISE INDICATED ON PLAN SIZE AS COMMON RAFTERS (IN EXCESS OF 16'-0" LONG USE DOUBLE COMMON RAFTERS)
- UNLESS NOTED OTHERWISE BOLT DOUBLE RAFTERS TOGETHER WITH 1/2"Ø. BOLTS AT 1'-4" C/C, BOLTS STAGGERED VERTICALLY.
- RIDGE BOARDS 1"x8" FOR 6" RAFTERS, 1"x10" FOR 8" RAFTERS, AND 1"x12" FOR 10" OR 12" RAFTERS.
- RIDGE POLE: FOR PEAK ROOFS 4"x4"
- TIMBER STRINGERS: 2"x6" MIN. FIXED TO WALL WITH 3/8"Ø BOLTS AT 2'-6" C/C RAFTERS TO BE SIDE FIXED TO STRINGERS WITH JOIST HANGERS WHERE EXPOSED BELOW.
- UNLESS NOTED OTHERWISE CRIPPLE BOARDS TO BE 1"x10" FOR 6" AND 8" RAFTERS, AND 1"x12" FOR 10" OR 12" RAFTERS.
- UNLESS NOTED OTHERWISE FIX WALL PLATE TO BELT BEAM WITH 1/2"Ø BOLTS J BOLTS IN 8" DIA. HOLES THROUGH WALL PLATE AT 2'-6" C/C (BOLTS SET MIN. 6" INTO CONC. RING BEAM).
- FIX EACH RAFTER TO WALL PLATE WITH FULLY NAILED 'SIMPSON STRONG TIE' HURRICANE CLIPS TYPE H2.5A PER RAFTER UNLESS NOTED OTHERWISE.
- ALL NAILS FOR PERMANENT WORK TO BE GALVANIZED.
- ALL BOLTS TO BE GALVANIZED STEEL OR STAINLESS STEEL.
- EAVE SLATE: STANDARD PC CONC. UNITS FIXED W/ 2-NO. 2 1/2" NO.10 BRASS SCREWS.
- RAINWATER GLIDES: 3"x4" STANDARD PC CONC. GUTTER STONES.
- MINIMUM CLEARANCE OF TIMBER TO CHIMNEY: 1/2".



NOV. 2023	1	ISSUED FOR PERMIT
MAY. 2023	-	ISSUED TO CLIENT
DATE	NO:	REVISION

BRUNEL
ENGINEERING CONSULTANTS

t: 441.297.6191 • info@brunel.bm • www.brunel.bm

PROJECT:
PURVIS PRIMARY SCHOOL
#44 ST. MARY'S ROAD
WARWICK PARISH, BERMUDA

TITLE:
GENERAL STRUCTURASL NOTES
& SCHEDULES

SCALE:	AS SHOWN	JOB NO:	23-015
DRAWN BY:	JC	DRAWING #:	S1.0
DATE:	MAY 2023		

DRAWING SCALE SHOWN IS FOR FULL-SIZE DRAWINGS. DRAWINGS PLOTTED ON 11"x17" SHEETS ARE HALF SCALE SHOWN (1/4"=1'-0" ON 24"x36" SHEET = 1/8"=1'-0" ON 11"x17" SHEET)

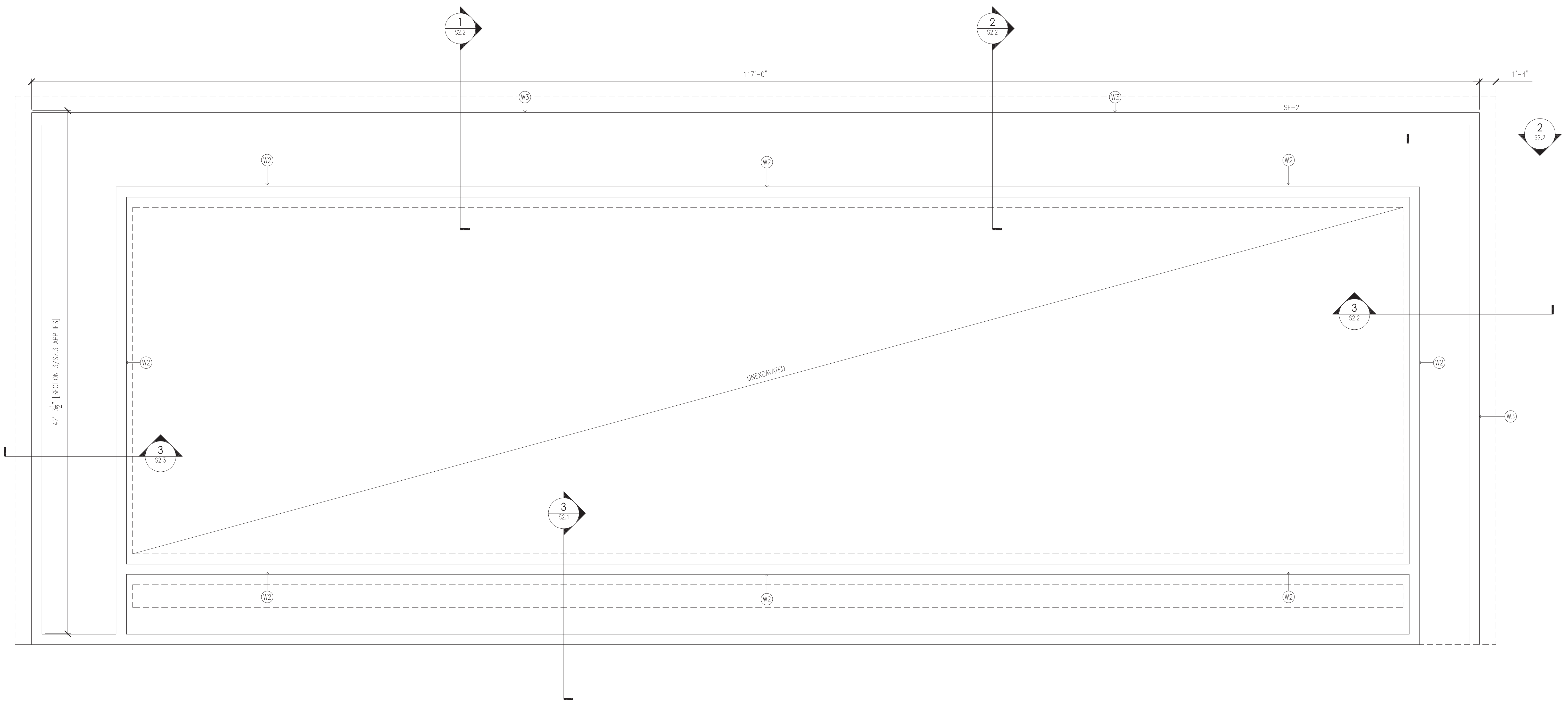

1 FOUNDATION PLAN
 S1.1 SCALE: 1/8" = 1'-0" (11"x17" SHEET)
 1/4" = 1'-0" (24"x36" SHEET)



 t: 441.297.6191 • info@brunel.bm • www.brunel.bm	PROJECT: PURVIS PRIMARY SCHOOL #44 ST. MARY'S ROAD WARWICK PARISH, BERMUDA	TITLE: FOUNDATION PLAN (PROPOSED)	SCALE: AS SHOWN DRAWN BY: MK DATE: MAY 2023 JOB NO: 23-015	DRAWING SCALE SHOWN IS FOR FULL-SIZE DRAWINGS. DRAWINGS PLOTTED ON 11"x17" SHEETS ARE HALF SCALE SHOWN (1/4"=1'-0" ON 24"x36" SHEET : 1/8"=1'-0" ON 11"x17" SHEET)	DATE: MAY 2023 NOV 2023	NO: - 1	REVISION: ISSUED TO CLIENT Issued For Permit	DRAWING #: S1.1

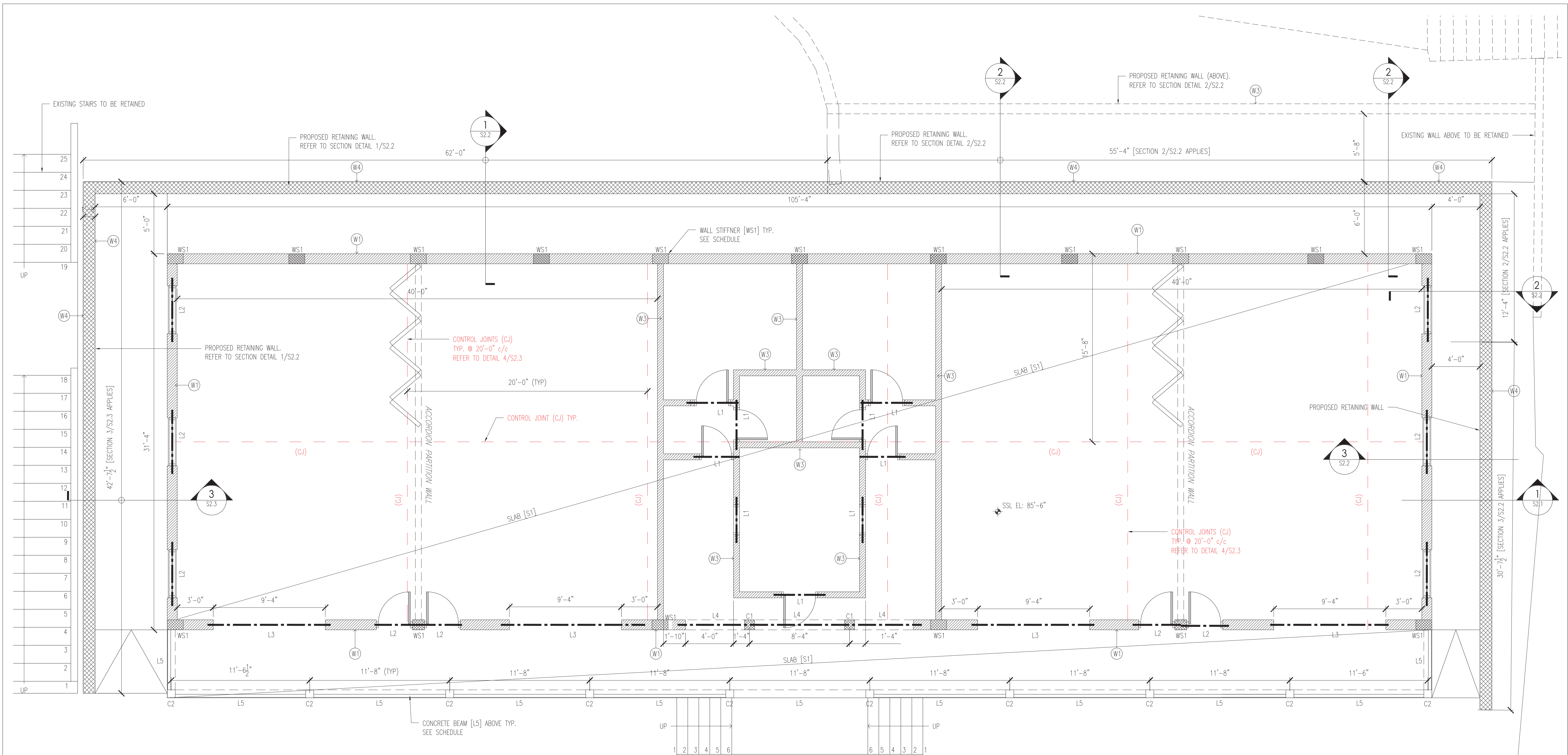

1 GROUND FLOOR PLAN
 (S1.2) SCALE: 1/8" = 1'-0" (11"x17" SHEET)
 1/4" = 1'-0" (24"x36" SHEET)



 t: 441.297.6191 • info@brunel.bm • www.brunel.bm	PROJECT: PURVIS PRIMARY SCHOOL #44 ST. MARY'S ROAD WARWICK PARISH, BERMUDA	TITLE: GROUND FLOOR PLAN (PROPOSED)	SCALE: AS SHOWN DRAWN BY: MK DATE: MAY 2023 JOB NO: 23-015	DRAWING SCALE SHOWN IS FOR FULL-SIZE DRAWINGS. DRAWINGS PLOTTED ON 11"x17" SHEETS ARE HALF SCALE SHOWN (1/4"=1'-0" ON 24"x36" SHEET : 1/8"=1'-0" ON 11"x17" SHEET)	DATE: MAY. 2023	NO.: -	REVISION: ISSUED TO CLIENT	DRAWING #: <h1>S1.2</h1>
					DATE: NOV. 2023	NO.: 1	REVISION: Issued For Permit	

STEEL BEAM SCHEDULE (ALTERNATIVE TO CONCRETE BEAM)

TYPE	LOCATION	SIZE	GRADE
SB-1	ABOVE UPPER FLOOR	W16 x 40	A50

STEEL BEAM NOTES

- BEAMS TO BE GRADE 50ksi STEEL UNLESS NOTED OTHERWISE. BEAMS TO BE COATED WITH A LAYER OF RED-OXIDE PRIMER.
- BEAMS TO BE FULL SPAN. NO SPLICING OF BEAMS WITHOUT ENGINEERS PRIOR APPROVAL.
- HOLES IN BEAMS TO BE SHOP DRILLED. NO GAS CUTTING PERMITTED. NO HOLES IN BEAMS PERMITTED UNLESS APPROVED BY ENGINEER.
- BEAMS TO BEAR ONTO CONCRETE BEARING PADS MINIMUM 16" x 8" x 8" REINFORCED AS NOTED.
- BLOCK CELLS BELOW EACH END OF BEAM ARE TO BE SOLID FILLED DOWN TO SLAB LEVEL AND REINFORCED WITH 2-T16 VERTICAL BARS.
- ENDS OF BEAMS TO BE CONCRETE ENCASED AFTER INSTALLATION.

WALL STIFFNER SCHEDULE

TYPE	SIZE	REINFORCEMENT	TIES
WS-1	WOW x 16"	2-T16 (VERT. BARS)	16 @ 16" CTS.

NOTE:

- ALL VERTICAL BARS TO HAVE 12" BEND INTO SLAB OR BEAM ABOVE AND SLAB/FOUNDATION BELOW.
- BLOCKWORK COLUMNS TO BE POURED IN MAXIMUM 4' HIGH LIFTS WITH THE POUR STOPPING 2" BELOW THE TOP OF THE BLOCK CELL TO ALLOW THE NEXT LIFT TO KEY TOGETHER. REINFORCING BARS ARE TO EXTEND A MINIMUM LAP LENGTH ABOVE THE TOP OF THE POUR.

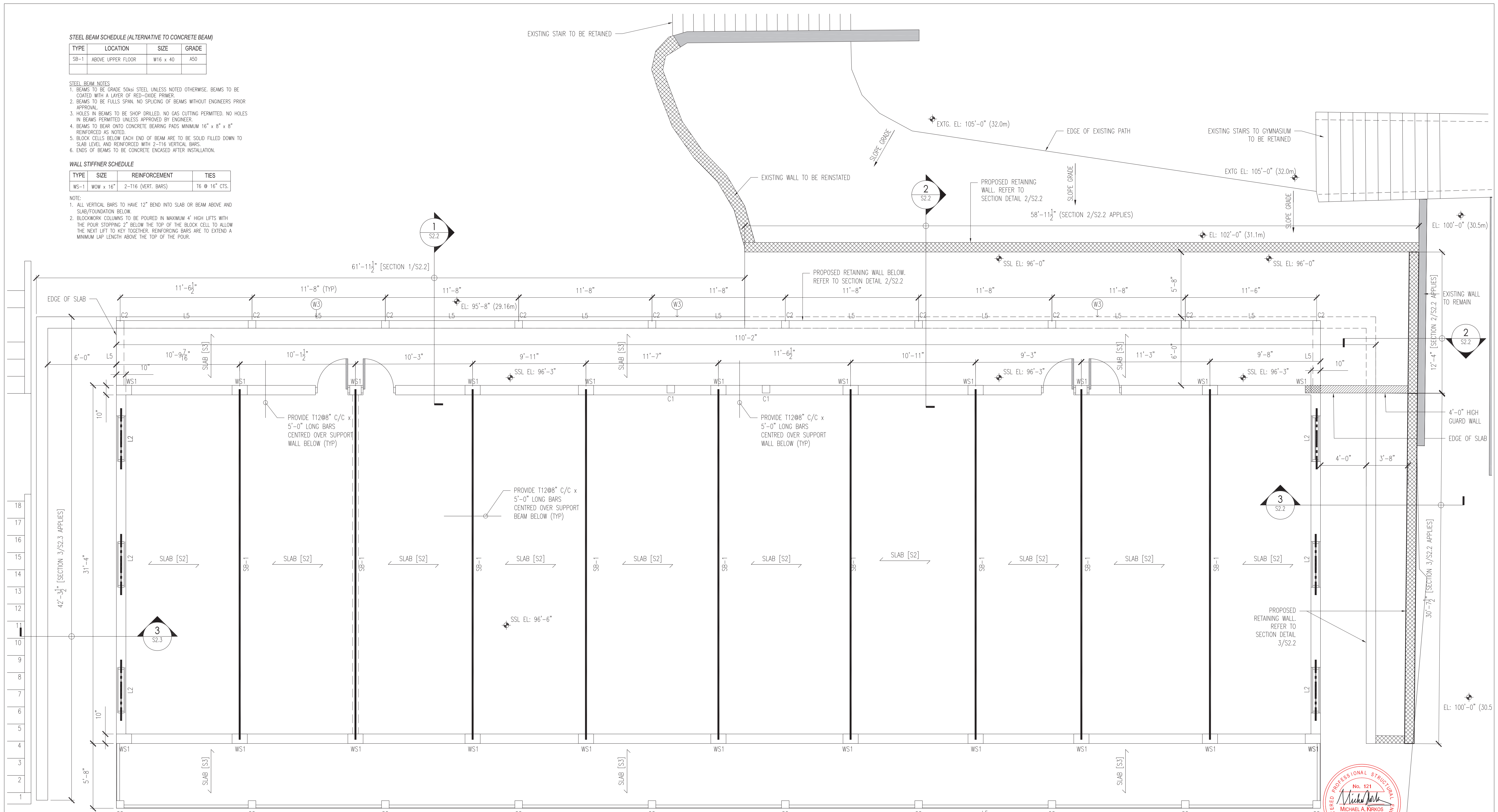

1 UPPER FLOOR PLAN
 S1.3 SCALE: 1/8" = 1'-0" (11"x17" SHEET)
 1/4" = 1'-0" (24"x36" SHEET)



PROJECT:
 PURVIS PRIMARY SCHOOL
 #44 ST. MARY'S ROAD
 WARWICK PARISH, BERMUDA

TITLE:
 ROOF PLAN
 (PROPOSED)

SCALE: AS SHOWN
DRAWN BY: MK
DATE: Oct 2023
JOB NO: 23-015

DRAWING SCALE SHOWN IS FOR FULL-SIZE DRAWINGS. DRAWINGS PLOTTED ON 11"x17" SHEETS ARE HALF SCALE SHOWN
 (1/4"=1'-0" ON 24"x36" SHEET : 1/8"=1'-0" ON 11"x17" SHEET)

DATE	NO.	REVISION
SEPT. 2023	-	ISSUED TO CLIENT

DRAWING #:
S1.3

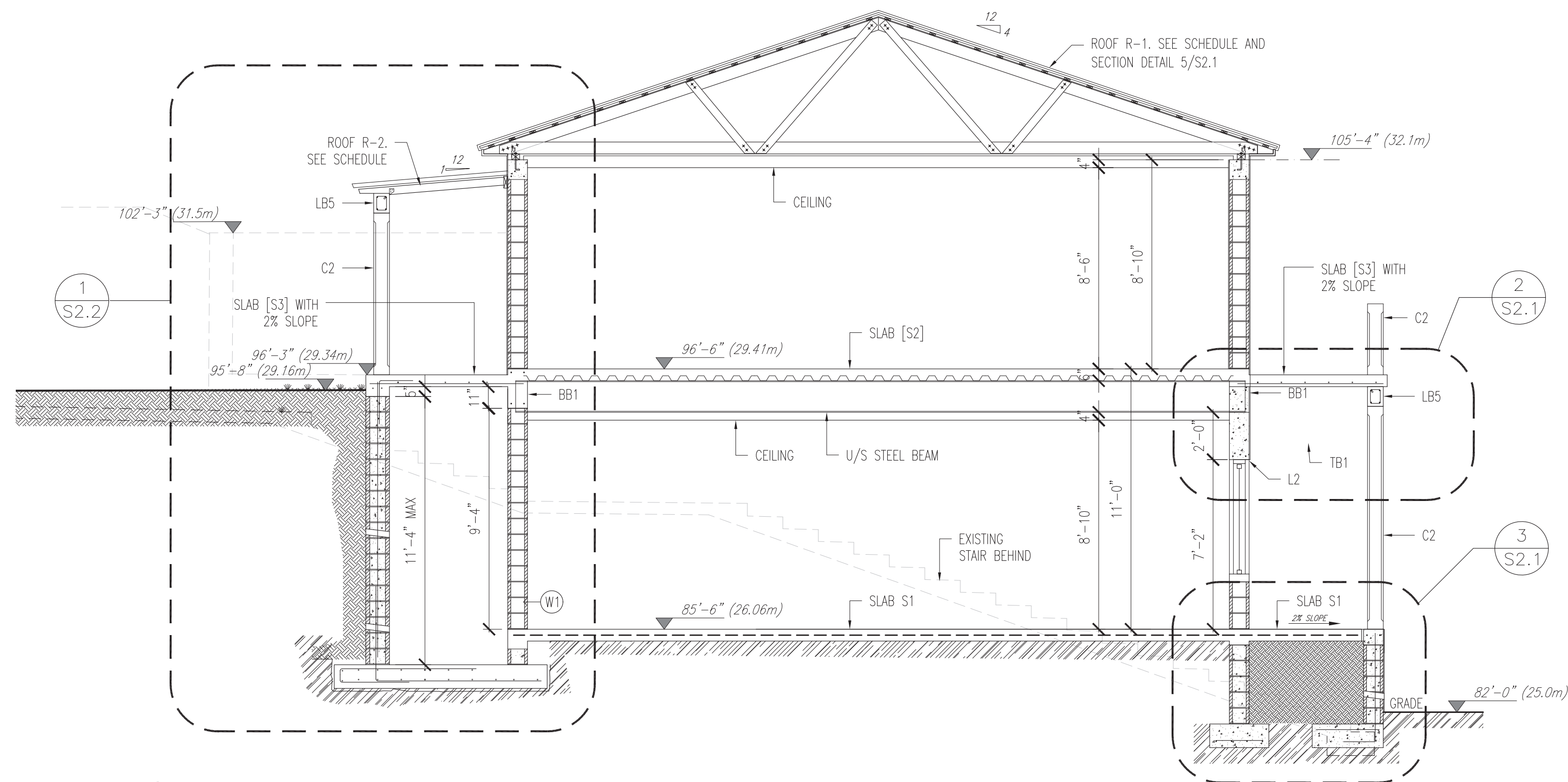

1 SECTION
 S2.1 SCALE: 1/8" = 1'-0" (11"x17" SHEET)
 1/4" = 1'-0" (24"x36" SHEET)

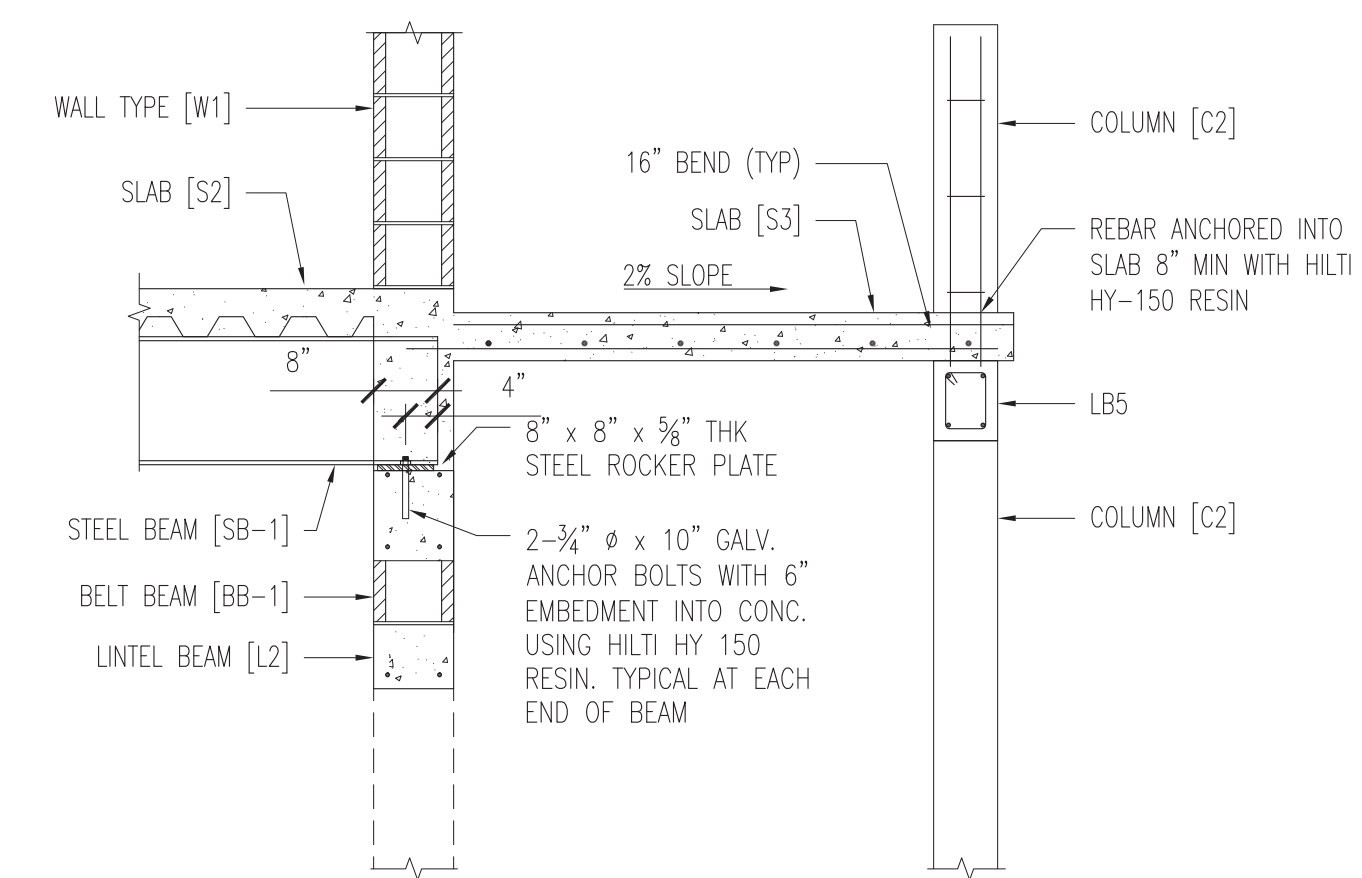

2 SECTION - DETAIL
 S2.1 SCALE: 1/4" = 1'-0" (11"x17" SHEET)
 1/2" = 1'-0" (24"x36" SHEET)

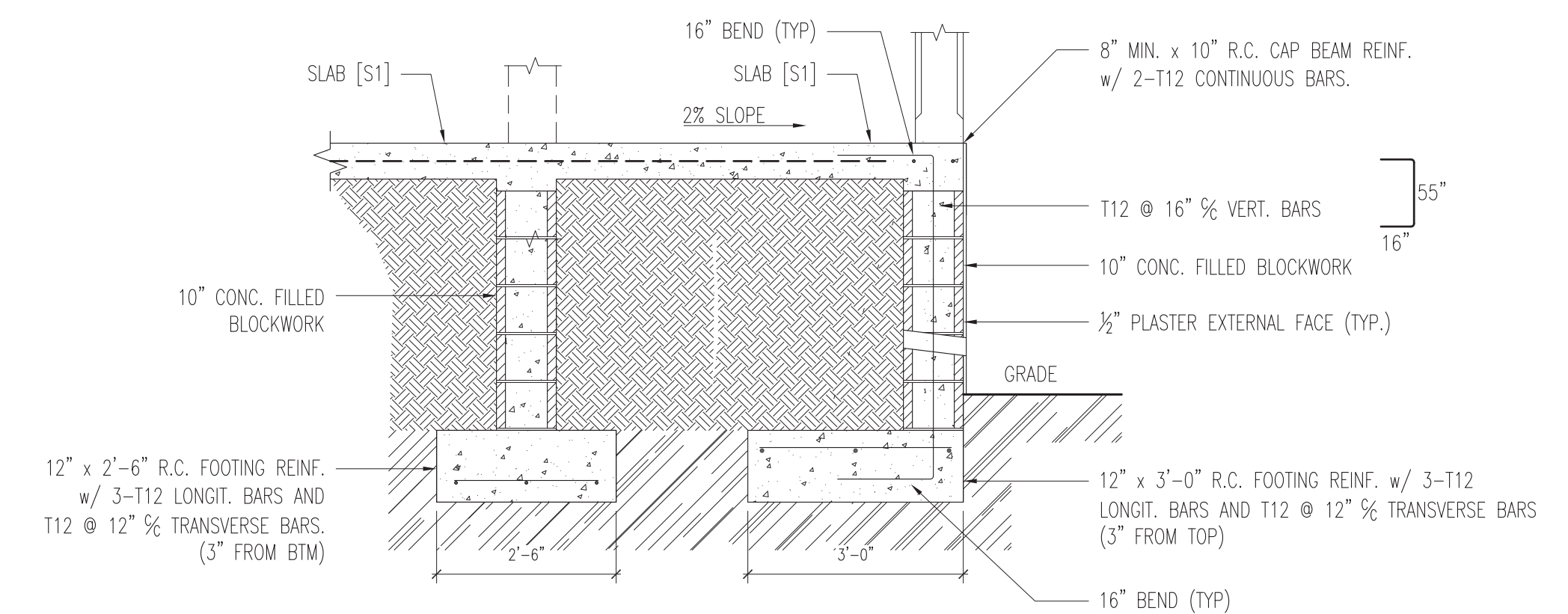

3 SECTION - DETAIL
 S2.1 SCALE: 1/4" = 1'-0" (11"x17" SHEET)
 1/2" = 1'-0" (24"x36" SHEET)

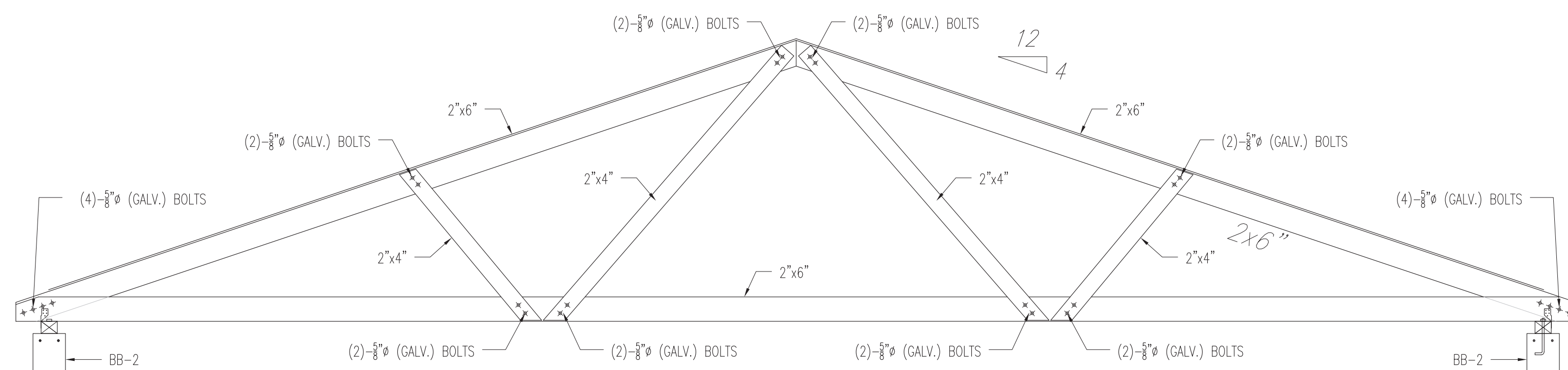

4 SECTION
 S2.1 SCALE: 1/4" = 1'-0" (11"x17" SHEET)
 1/2" = 1'-0" (24"x36" SHEET)



t: 441.297.6191 • info@brunel.bm • www.brunel.bm

PROJECT:
 PURVIS PRIMARY SCHOOL
 #44 ST. MARY'S ROAD
 WARWICK PARISH, BERMUDA

TITLE:
 SECTION (PROPOSED)

SCALE: AS SHOWN
 DRAWN BY: MK
 DATE: MAY 2023
 JOB NO: 23-015B

DRAWING SCALE SHOWN IS FOR FULL-SIZE DRAWINGS. DRAWINGS PLOTTED ON 11"x17" SHEETS ARE HALF SCALE SHOWN
 (1/4"=1'-0" ON 24"x36" SHEET : 1/8"=1'-0" ON 11"x17" SHEET)

DATE	NO.	REVISION
MAY, 2023	-	ISSUED TO CLIENT
JULY 2023	1	REVISED AS CLOUDED

DRAWING #:

S2.1

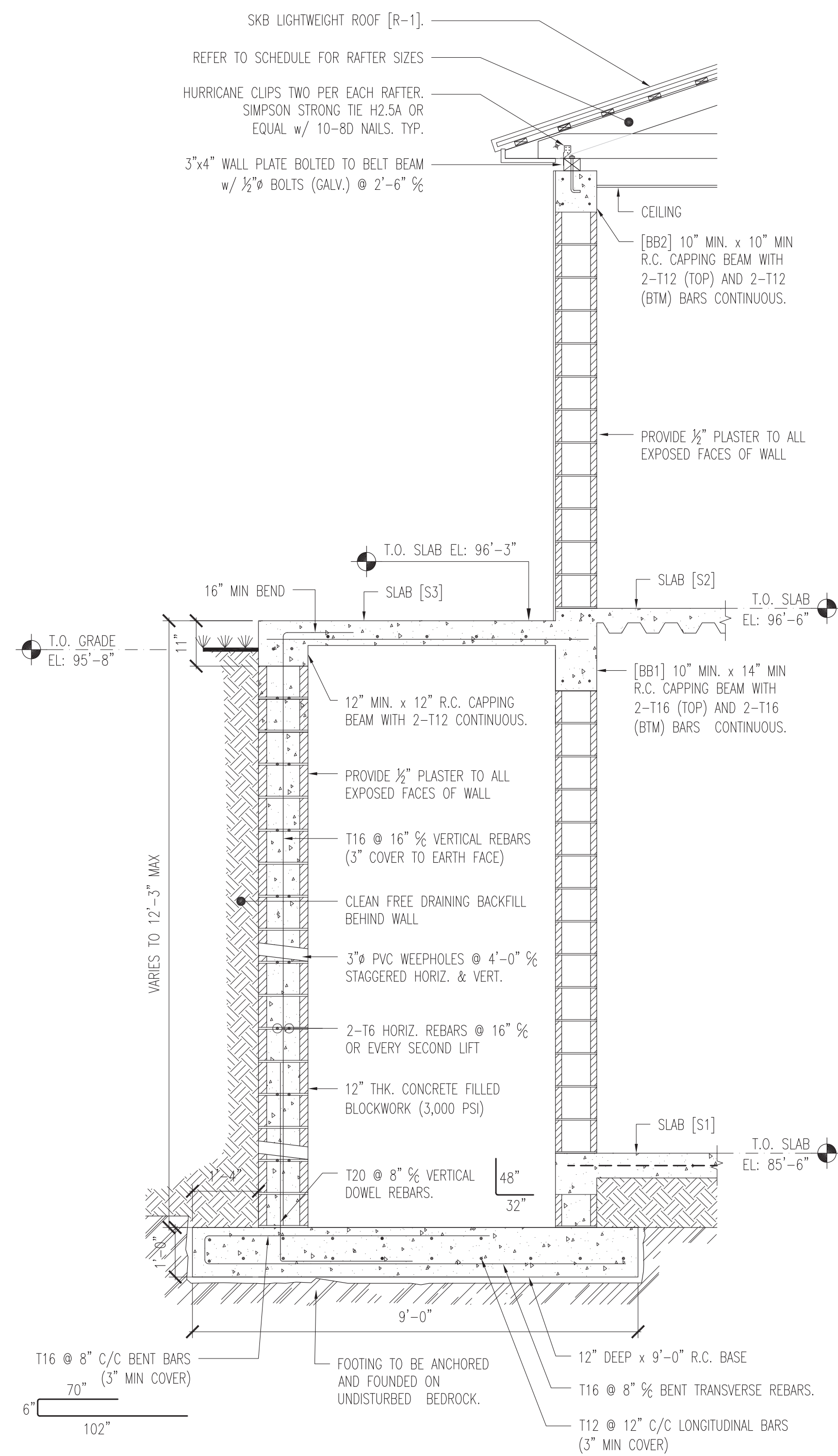

1 SECTION
 S2.2 SCALE: 1/4" = 1'-0" (11"x17" SHEET)
 1/2" = 1'-0" (24"x36" SHEET)

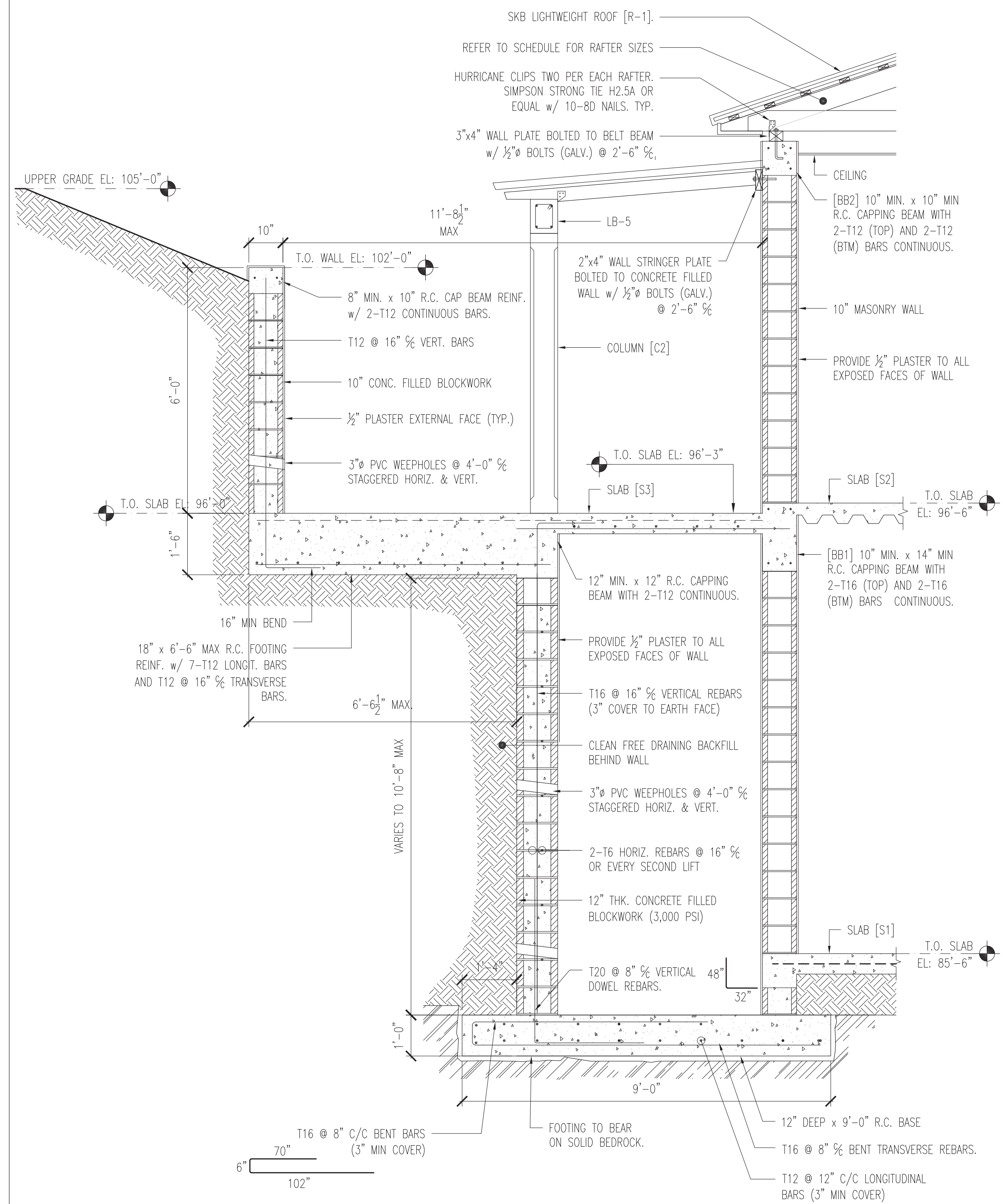

2 SECTION
 S2.2 SCALE: 1/4" = 1'-0" (11"x17" SHEET)
 1/2" = 1'-0" (24"x36" SHEET)

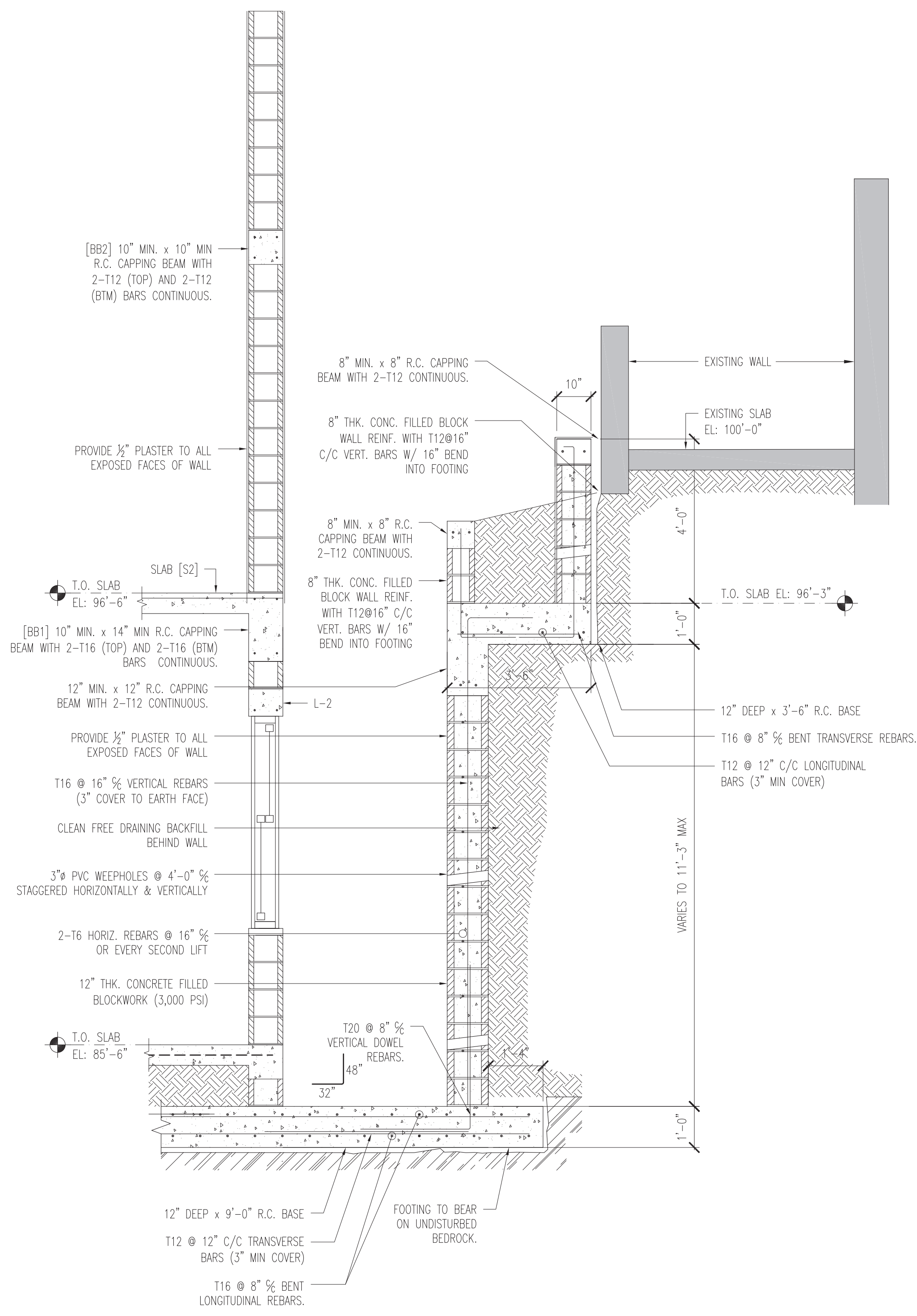

3 SECTION
 S2.2 SCALE: 1/4" = 1'-0" (11"x17" SHEET)
 1/2" = 1'-0" (24"x36" SHEET)



PROJECT:
 PURVIS PRIMARY SCHOOL
 #44 ST. MARY'S ROAD
 WARWICK PARISH, BERMUDA

TITLE:
 SECTION DETAILS

SCALE: AS SHOWN
 DRAWN BY: MK
 DATE: MAY 2023
 JOB NO: 23-015B

DRAWING SCALE SHOWN IS FOR FULL-SIZE DRAWINGS. DRAWINGS PLOTTED ON 11"x17" SHEETS ARE HALF SCALE SHOWN
 (1/4"=1'-0" ON 24"x36" SHEET : 1/8"=1'-0" ON 11"x17" SHEET)

DATE	NO.	REVISION
JULY 2023	-	ISSUED FOR BUILDING PERMIT

DRAWING #:

S2.2

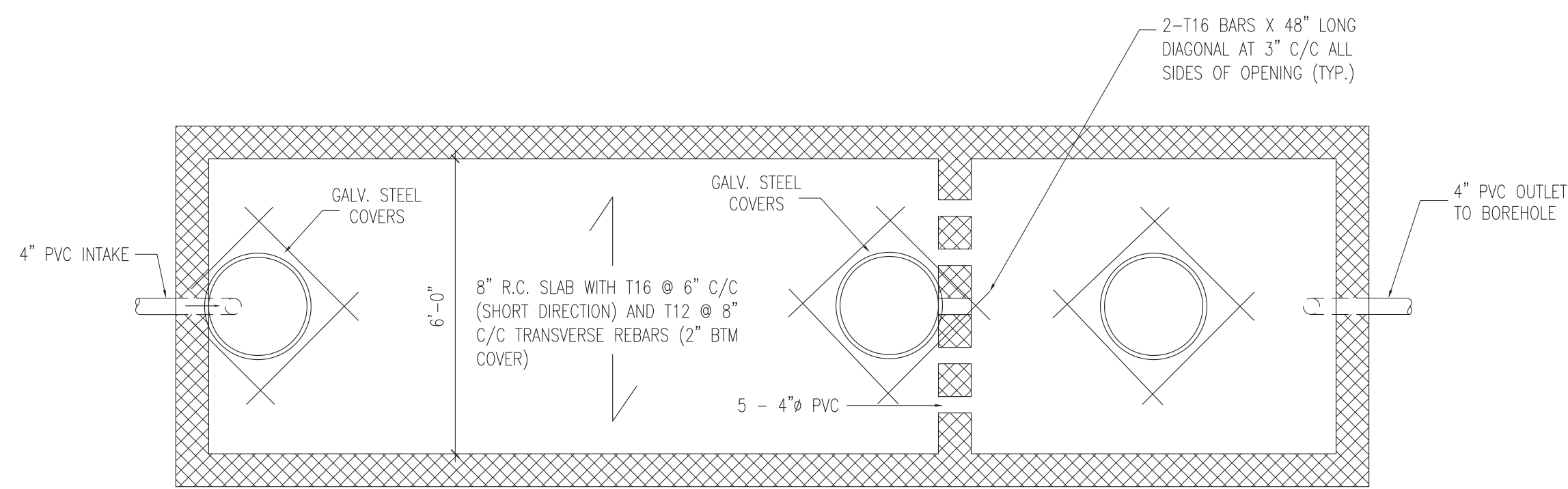

PLAN VIEW

8" FILLED CONC. BLOCK WITH T12 @ 8" C/C VERT. REBARS

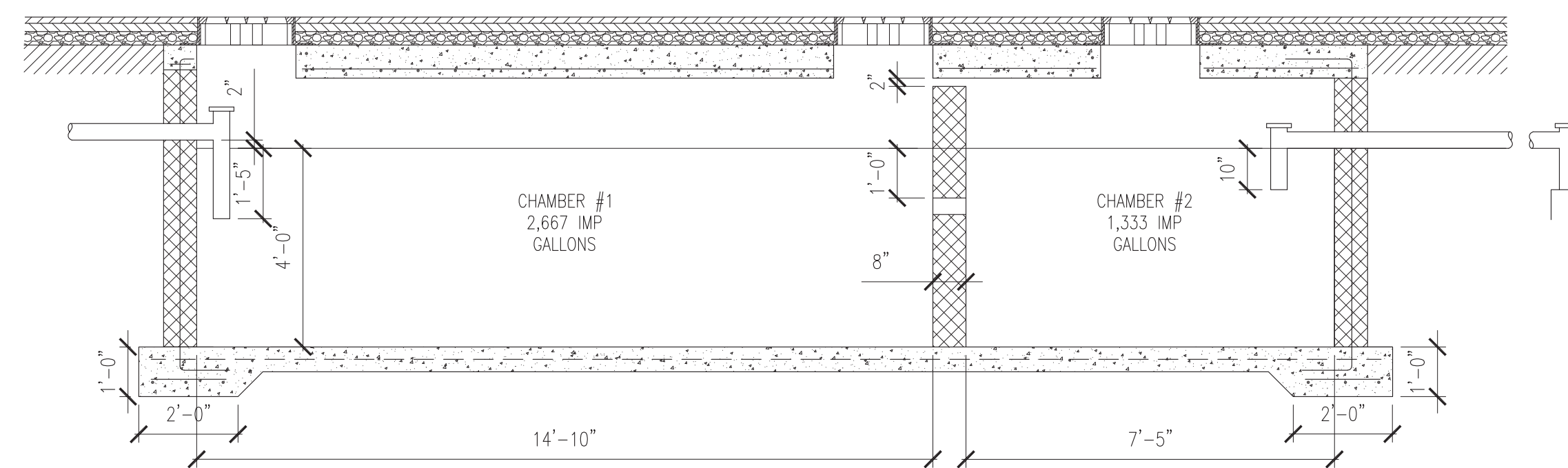

SECTION VIEW

1 SEPTIC TANK (4,000 GALLONS)
S2.3 SCALE: 3/16" = 1'-0" (11"x17" SHEET)
3/8" = 1'-0" (24"x36" SHEET)

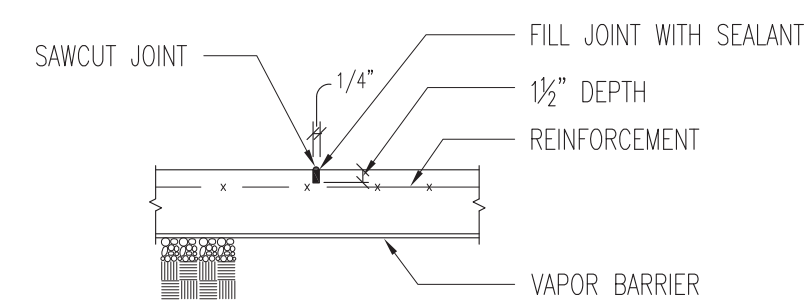

NOTES:
1) CONTROL JOINTS TO BE PLACED @ 20'-0" C/C OR LESS.

4 SECTION
S2.3 SCALE: 1/4" = 1'-0" (11"x17" SHEET)
1/2" = 1'-0" (24"x36" SHEET)

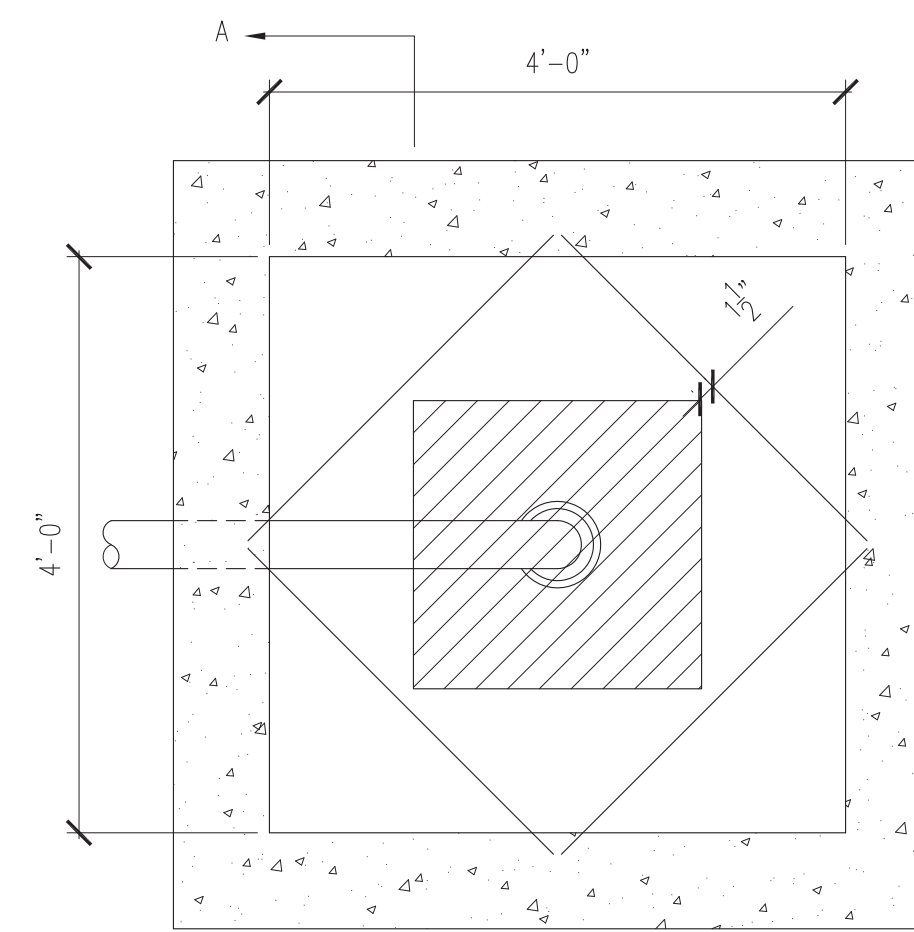

PLAN VIEW

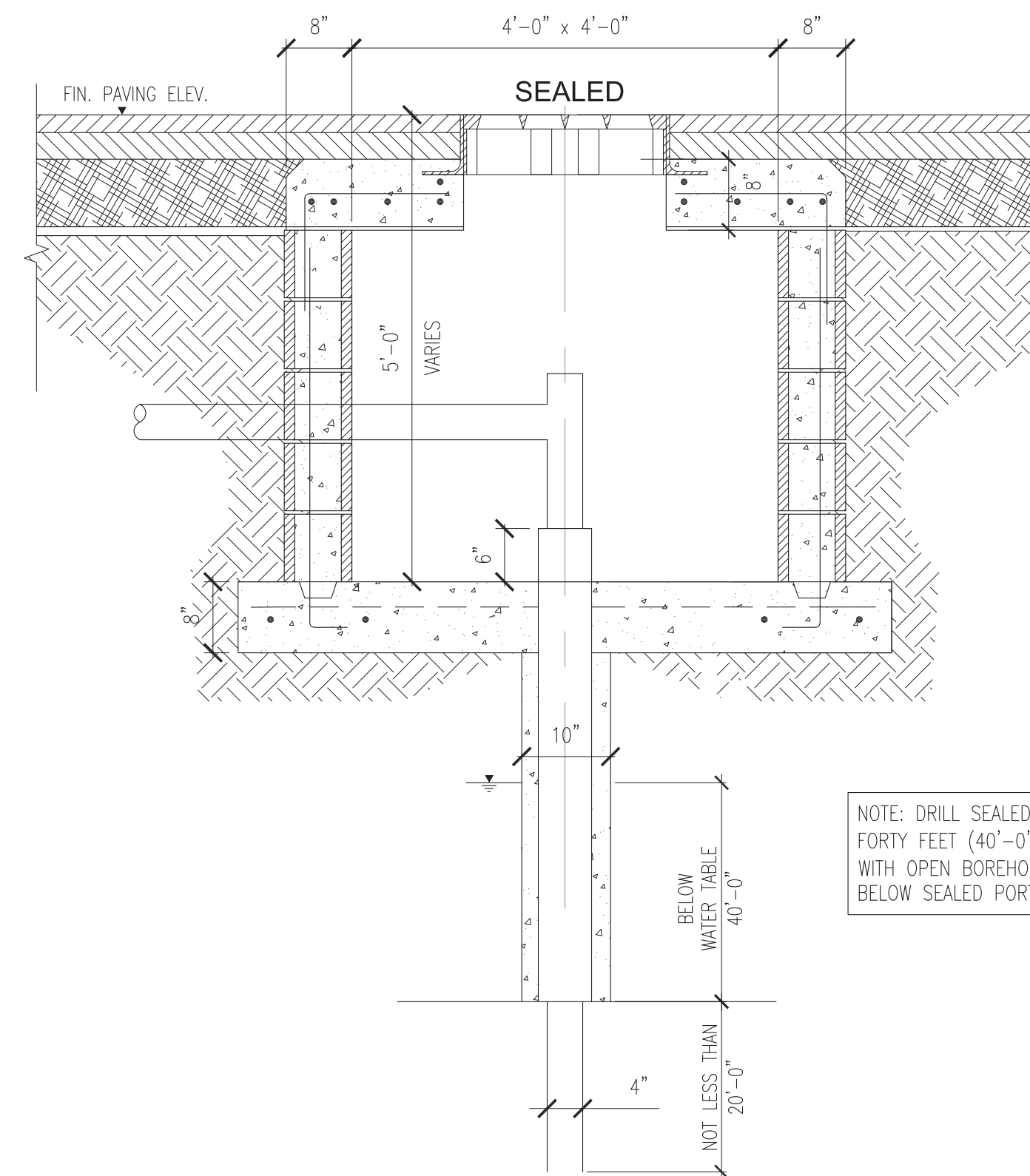

2 TYPICAL WASTE WATER DISPOSAL BOREHOLE
S2.3 SCALE: 3/8" = 1'-0" (11"x17" SHEET)
3/4" = 1'-0" (24"x36" SHEET)

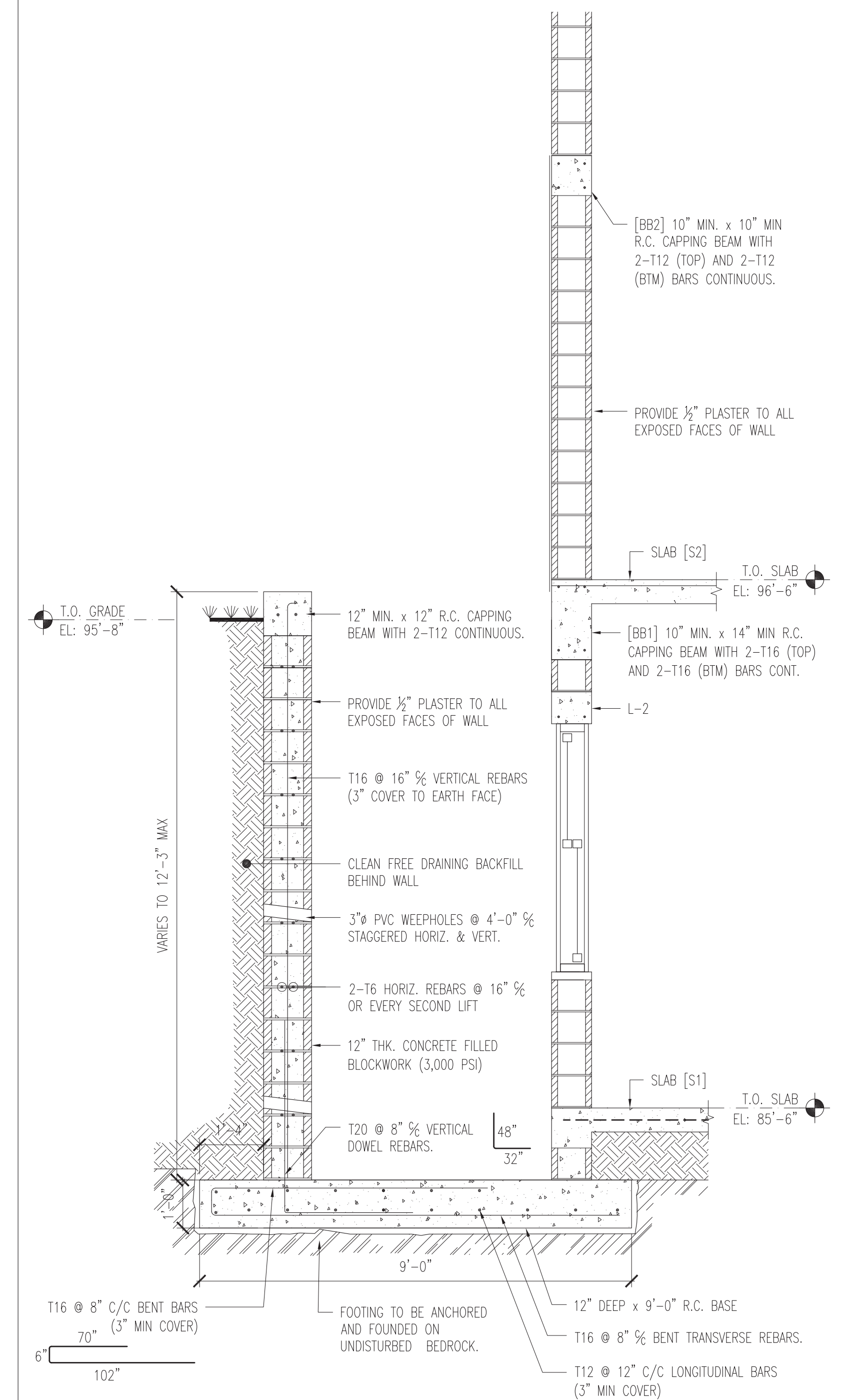

3 SECTION
S2.3 SCALE: 1/4" = 1'-0" (11"x17" SHEET)
1/2" = 1'-0" (24"x36" SHEET)

